

# THE LAND REPORT

Number 3

September, 1977

## Paul Sears to Visit The Land

Dr. Paul B. Sears, a well-known botanist-ecologist and conservationist, will visit The Land October 11-12 and speak at the Salina Community Theatre on the evening of October 11.

Paul Sears has served on the faculties of Ohio State University, the Universities of Nebraska and Oklahoma, and Oberlin College, and has been chairman of the Conservation Program at Yale. Though now retired from teaching, he is still active in promoting conservation.

Dr. Sears is the author of a number of books; among these are Deserts on the March, This is our World, Life and Environment, and Charles Darwin, the Naturalist as a Cultural Force. Perhaps the most famous of these has been Deserts on the March, first published in 1935 and still in print today.

A United Nations Conference on Desertification was held the first week in September, 1977, in Nairobi, Kenya. The 1,500 delegates from more than 100 countries were presented with data showing that fourteen million acres of fertile, productive land is being denuded and destroyed each year, and unless this process of desertification is halted, one-third of today's arable land will be lost during the next twenty-five years, while the world's need for food will nearly double. Deserts are still on the march, and Dr. Sears' concerns expressed in 1935 are even more relevant in the 1970's.

Dr. Sears' address on October 11 is sponsored by The Land Institute in cooperation with the Smoky Hills Audubon Society and is open to all the public.



Giulio Tambalo, John Jankowski, Wes Jackson and John Craft ask Fred Kale of Hiawatha, Kansas (center of Photo) about his wind machines. This stop in Hiawatha was part of a summer field trip which also included a visit to the organic farm of John Vogelsberg in Home City, Kansas, and a visit with Bob McBroom in Holton, Kansas, to see the wind energy system which powers his shop.

## A Food Co-op in Salina?

Several food co-ops have been organized in Salina, but for one reason or another they have all been dissolved. When we began talking to friends of The Land about purchasing foods in bulk and distributing them as part of a non-profit enterprise, they were dubious about its chances of success. We decided that it would be a good idea to gather information about whole natural food stores and study co-ops which are now functioning before we attempted a new venture.

Through a private grant to The Land Institute, Jan Peters began the food co-op study in July. She talked to the managers of food co-ops in Wichita, Manhattan and Lawrence and visited Letoba Farms near Lyons, Kansas. She learned about the Ozark Co-op and other distributors of bulk natural foods. Literature about food co-ops, organic foods, and food preparation was collected. After this investigation, Jan prepared a questionnaire which was distributed to approximately 400 residents of Salina and nearby communities.

In the letter accompanying the survey, Jan explains the type of store we would wish to establish. "The food store we have in mind would carry high quality products. We would handle as many organically grown foods as possible. By "organic" we mean crops which have been raised without the use of chemical fertilizers or pesticides. We would not carry

(contd. on page 3)

## In This Issue

Dr. E. F. Schumacher is Dead.....	2
Schumacher on Trees.....	2
Annual Meeting Held.....	3
Wes Jackson to be Guest Lecturer.....	3
South Asian Transnational Dialogue.....	3
Rebuilding Wind Generators.....	4
Junked Cars and Wind Machines.....	5
Manufacturing Potential of Wind Energy Systems.....	6
Adobe Block Experiments Continue.....	6
Solar Heating in the "Doings" Building.....	7
Special Programs at The Land.....	7
How Does Our Garden Grow?.....	8
Learning in the Organic Garden.....	9
Getting Acquainted with the KOP.....	9
A Frame of Mind.....	10
Towards Tomorrow Fair '77.....	10
Kansans Protest Nuclear Power.....	11
University for Man Class at The Land.....	12
Friends of The Land.....	12



## Dr. E. F. Schumacher is Dead

Dr. E. F. Schumacher died September 4 while traveling in Switzerland. He was sixty-six years old.

Dr. Schumacher was a well-known economist who served on the British Coal Board for many years. His book, Small is Beautiful, Economics as if People Mattered, brought him international renown. As one of the founders of Intermediate Technology in Great Britain and honorary chairman of Intermediate Technology in Menlo Park, California, he was the outstanding spokesman for the intermediate or appropriate technology movement.

In March, 1976, E. F. Schumacher visited The Land and gave an address at the Salina Community Theatre to an overflow audience. During his visit, he agreed to become an honorary member of the Board of Directors of The Land Institute. This has been very meaningful, as Dr. Schumacher was associated in this manner with only two groups in the United States, Intermediate Technology of Menlo Park and The Land Institute.

Dr. Schumacher was a humanist-environmentalist, who inspired those he met and significantly influenced attitudes and social institutions in this country. During his twelve state tour, he spoke to grass root conferences, university audiences, the scientists at the AAAS convention, and government officials ranging from Indian tribal leaders to state governors, city officials to President Carter. He was not accused of being a doomsday prophet, as his message emphasized that if we act now we can make preparations for a future of shortages in food, fuel and materials that will be enhancing to the human spirit, rather than degrading. Yet, on the way back to the Hilton Inn after his Salina address, he stopped suddenly on the sidewalk, put his hand to his head, and said to Wes Jackson, "My God, do we have time?"

A special memorial service was held on September 6 in Grace Cathedral, San Francisco, where Dr. Schumacher gave a Sunday sermon last March. Money given as a memorial to Dr. Schumacher will be used to plant trees.

In loving memory of Dr. E. F. Schumacher, we are reprinting from the Intermediate Technology Report 4/5 the transcript of part of a speech given by Dr. Schumacher in Washington D. C. on March 21, 1977. (Copyright, E. F. Schumacher, 1977)

## Schumacher on Trees

Well, we could go on conversing these matters for a long time, but I will end by giving you an example of an ideal and possibly one of the most productive "soft" technologies that can be conceived. One of the greatest gifts the Lord gave to this earth is trees. And it is strangely one of the subjects where man has been most negligent, most ruthless, and most stupid. Much of the devastation caused by man can be traced to the neglect of trees. In the Mediterranean, the whole of Asia Minor, much of India and in many parts of Asia you will find in all of the records that these countries were flowing with milk and honey as long as they had plenty of trees. But then the tree has a life cycle that is a bit longer than the human cycle, and people have taken attitudes that they really couldn't care less about trees for the future. Let's get the timber or whatever right now, and let the devil take the hindmost. Well, the devil has taken the hindmost, and we can't afford it anymore.

The Buddha in India, when India was a land flowing with milk and honey, made a rule that every good Buddhist should plant a tree once every five years of his life. And so there was no problem. There was enough fuel and there was enough shade and there was enough water, and of course there was enough unbelievably useful trees not only for timber, not only for fruit, but also for food.

Now I believe that we will not be able to avoid a very severe food crisis which will be all tied up with the energy crisis. We can better prepare for it by taking seriously the possibility of growing a lot of food on trees of various kinds, including carob, honey locust, and all sorts of extremely useful trees. It takes some time if you embark on a long journey, and the only advice that one can give is that you should get up early. We have all been sitting under trees planted by our ancestors, so let us plant trees so that our children and grandchildren can sit under them and possibly get the harvest. The interesting thing about this which now becomes more understandable is that the tree is a three-dimensional solar collector and is of such miraculous powers that only people that have done the grafting and breeding work fully realize. The first thing to do is for people to really get busy in a popular democratic movement everywhere to establish a tree wherever there is unused land, a tree that is potentially useful, a tree that can produce food, not only timber. Once we have the stock established, then there will be sufficient interest to do the work of selection and even plant breeding to make the best of it. This is the subject that has been so neglected in regard to useful

(contd. on page 3)

(contd. from page 2)

food producing trees. When it has been undertaken, with the rubber tree for instance, of course the results have been overwhelming. The plant breeders have developed the noble rubber tree whose productivity is a high multiple of the natural rubber tree.

I'd like you to think about this, and think about it when you look out a window, when you travel in the country, just how much ground there is where there ought to be trees. And what a marvelous thing it would be if we could really establish that as a normal part of celebration, we establish a tree. Once we have enough useful stock established, then we can go on ennobling these trees by the noble art of grafting. Well, ladies and gentlemen, that is my story. I thank you for your attention.

A Guide for the Perplexed, E. F. Schumacher's newest book, was released by Harper and Row this month and should now be in the bookstores.

## Annual Meeting Held

At a meeting on July 25th, the members of The Land Institute voted to accept the resignation of Rev. W. E. Cassell from the Board of Directors. His support during the first year The Land Institute was organized has been of inestimable value.

Karen Black, a Salina attorney, was elected to fill the vacant board position. Upon graduation from the University of Kansas in journalism, Karen served as a Vista volunteer on the Lower Brule Indian Reservation in South Dakota. She then worked for several years for the Salina Journal. In 1976 she received her law degree from Washburn University Law School. She and her husband John are partners in a law firm in Salina.

Members of the Board of Directors of The Land Institute elected to serve for another year were Wes Jackson, Dana Jackson, John Simpson, Sam Evans, Bernd Foerster, Gordon Maxwell, Wendell Nickell, John Schwartz, Steve Burr, Frank Anderson and Nancy Miller.

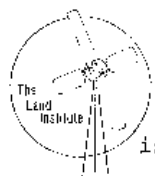

## THE LAND REPORT

is published three times a year by

The Land Institute  
Rt. 3  
Salina, Kansas 67401

Editor- Dana Jackson

Contributing to this edition: John Jankowski, John Craft, Marty Peters, Mike Weiss, Mary Harbin, Jim Lukens and Wes Jackson.

Photography- Mike Weiss  
Art- Sue Leikam

Subscription rate- \$3.00

The Land Institute is a non-profit educational research organization devoted to a search for alternatives in agriculture, energy, shelter and waste.

(contd. from page 1)

highly-processed, excessively-packaged, or chemically-preserved foods. In most cases, foods which are purchased in bulk and packaged in the store can be obtained more cheaply than in the supermarket. However, in some cases, organically grown foods might cost slightly more. We would strive to provide the highest quality food at the lowest possible price."

The next step is to evaluate the response to the survey to help determine the feasibility of establishing a food co-op. Anyone who did not receive a survey, but is interested in the co-op, should contact Jan Peters at 1512 Hickory, phone 827-9943. Those who did receive the questionnaire, please return it promptly to Jan.

Jan Peters will conduct a class for the Little House Adult Education Program at Memorial Hall on September 26 at 7:30, called "The Food Co-op Experience." Everyone who is interested in more information or in discussing the food co-op is invited to attend.

## Wes Jackson to be Guest Lecturer

Wes Jackson has been invited to be a part of the Fitzroy Memorial Visiting Scholar Program of the University Center in Virginia. From September 26-28 he will present lectures at several of the fifteen member institutions of the University Center in Virginia.

The National Association of Biology Teachers has also invited Wes to give a lecture at the 1977 national convention to be held in the Anaheim Convention Center in Anaheim, California, October 20-23. The theme for the convention is "Bioethics--from Genes to Biomes." Wes will be scheduled to speak in the Environmental Bioethics Symposium.

## South Asian Transnational Dialogue

The Overseas Development Council in Washington D. C. has invited Dana Jackson, Associate Director of The Land Institute, to be a participant in their South Asian Transnational Dialogue. Participants will depart New York City on October 21 and return November 8. Half the traveling time will be spent in India; half will be spent in Sri Lanka. The preliminary itinerary includes visits to agricultural and community projects in villages near Delhi, Bombay and Madras in India and near Colombo and Kandy in Sri Lanka.

One of the general objectives of the Transnational Dialogue is to help a broad American audience understand how people in developing countries feel about their efforts to achieve economic, political and social development, and to understand the relationship between those efforts and America's own economy and society. More specifically, the dialogue will be focusing on the international implications of self-reliant development in South Asia. Participants will be provided an opportunity to broaden their knowledge and insight about food and development in South Asia and the United States.

### Rebuilding Wind Generators

I came to The Land in mid-June with much interest in wind-generated electricity, but little successful experience. During the next five weeks, I worked on five different types of wind generators.

The first morning I was at The Land we began renovation of a small, six volt Wind-charger, originally used to charge batteries for radios. The generator and air brake assembly were in good shape, but the propellers were badly weathered and splintering. A light sanding, a layer of fiberglass resin cloth, more sanding, and three coats of paint made the propeller as slick as a new one.

My second experience was with the 32 volt Air charger, put up by Kyle Mansfield during the first semester. It had quit charging. We took the generator down from the tower, checked it out for short circuits, had the armature and stator baked and then dipped in laquer, and the commutator turned down on a lathe. After putting a new coat of paint on the blades, we reinstalled the generator with new leads from the generator to the tower, and found it charging to its full capacity again.

I had long desired to work with a Jacobs wind generator. The Jacobs is considered by many to be the most efficient and durable wind generator built. Thanks to the support and assistance of Leo Bircher of Kanopolis, Kansas, I was able to learn more about it. Leo loaned The Land a Jacobs which he had acquired, and with his help and suggestions, the generator has been completely reconditioned. We had it baked and dipped, installed new bearings and brushes, turned the commutator down, and checked it for charging capability. It is now nearly ready to be placed on its tower.

Bob McBroom of Holton, Kansas, supplied much interesting information about wind energy and another brand of the old wind generators, the Winpower. This is a downwind machine with a uniquely simple governing device. The same procedures described above were followed in reconditioning this generator.

A second Jacobs, of a larger size, was purchased. This machine has also been reconditioned, but the hub and governing mechanism, and the propeller blades were all damaged beyond repair. A used set of blades has been acquired, and Leo Bircher is constructing a new hub assembly.

With all of the wind energy whistling by The Land, and with all of the work being done on different wind generators, it was only natural to want to put the available energy and resources to useful work. We welded some six inch steam pipe together to make two towers, one fifty feet tall and one forty feet tall. We erected the towers and stabilized them with aircraft cable guy wires. These towers now loom above the hilltop, awaiting their respective wind machines. When the generators are in place, the entire upper half of the "Doings Building" will be lighted and powered by electricity produced from the wind. And that, after all, is the purpose of a wind generator.

John Craft

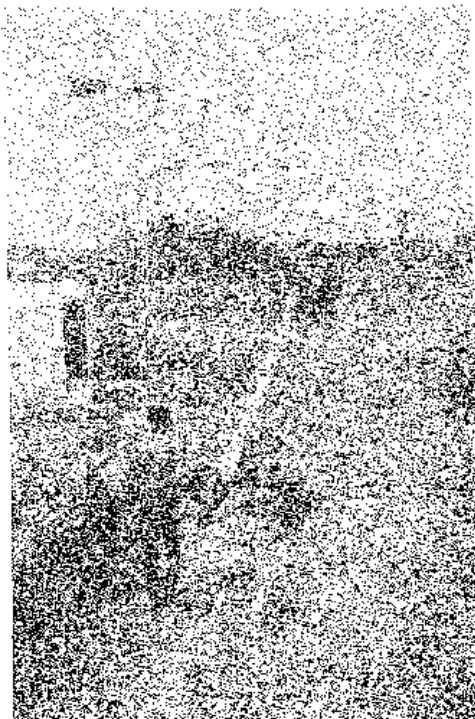

Scott Jackson, John Craft and Wes Jackson move the tower toward its place on the hill.



"Nature is not to be conquered save on her own terms. She is not conciliated by cleverness or industry in devising means to defeat the operation of one of her laws through the workings of another. She is a very business-like old lady, who plays no favorites. Man is welcome to out-number and dominate the other forms of life, provided he can maintain order among the relentless forces whose balanced operation he has disturbed. But this hard condition is one which, to date, he has scarcely met. His own past is full of clear and somber warnings-- vanished civilizations buried, like dead flies in lacquer, beneath their own dust and mud."  
(from Deserts on the March by Paul B. Sears)

(Left) Dennis DeBacker, engineer friend of The Land from Sacramento, California, helps John Craft balance the blades.

# Junked Cars and Wind Machines

Salvage yards (junk yards, if you insist) have always fascinated me. These recycling centers for vast arrays of gears, bearings, shafts, engines, and wheels, mostly from old or wrecked automobiles, provide a cheap source of precision-machined, versatile parts. The idea of using car parts to construct a wind generator occurred to me as I watched the splintered propeller of a wind machine made from bicycle parts flutter slowly back to earth. I vowed then to build the next wind generator "for stout."

A front spindle axle from a Ford Falcon was purchased at the salvage yard for \$2.50. Three-fourths inch water pipe was welded on the brake drum to take the propeller shaft, and two inch pipe was welded to the spindle to hold the unit out away from the tower. An old chain cog and a pulley from an old combine, with a little bit of angle iron and sheet metal for the tail, completed the head structure. Car alternators or generators became the electrical source. I roughed the propeller blades out of ash wood on a radial arm saw, then hand-planed and sanded them. Thick steel bars acted as weights activated by centrifugal force to "feather" the blades and thus control speed. Total cost of the system, including an old windmill tower, was less than \$50.00.

I have been experimenting with the unit since it was put up in May, first at my home south of Hillsboro, Kansas, then at The Land. The roller chain drive I first used proved to be too noisy; a "V" belt is now being used. I will continue to make adjustments and changes in this wind machine as ideas for improvements surface.

Future plans include making a larger unit which will drive three or four alternators. The wind machine which is up now has a propeller eleven feet in diameter and can produce approximately 1000 watts. Fifteen feet propeller blades will give an output of over 2000 watts at relatively slow windspeeds. Such a unit would supply all the electrical needs of our small home near Hillsboro.

John Craft

EDITOR'S NOTE: John Craft has received a \$1500 study grant from the National Center for Appropriate Technology to do a survey of available wind energy system components. He will determine which commercially available parts such as generators, towers, bearings, and propellers could be adapted for wind energy systems.

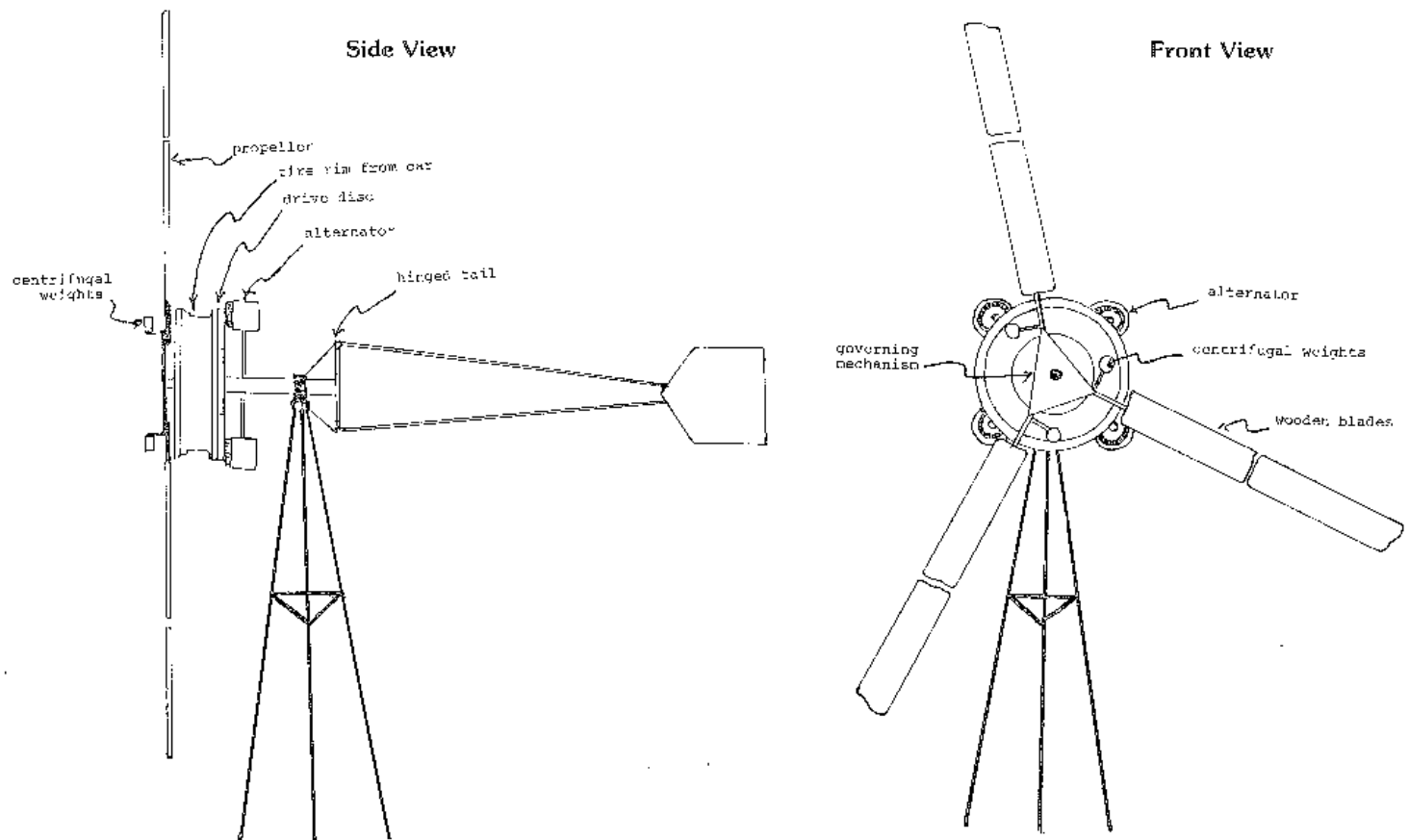

"However, the crux of this confusing argument between opponents and supporters of nuclear power is not so much each group's view of the probabilities of a nuclear accident; rather, it is whether taking that small risk is justifiable, given that other alternatives--including conservation--are available."

(from The Genesis Strategy by Stephen Schneider with Lynne Mesriow.)

## Manufacturing Potential of Wind Energy Systems

Through two private grants to The Land Institute, I am compiling a data base to support decisions involving the initiation of a local operation specializing in wind energy systems. The data base will include market research results, economic analyses and projections, and local manufacturing potential.

There is a long list of reasons for pursuing the development of wind energy. It is a pollution free, renewable energy source. It lends itself well to decentralization, the advantages of which are very well described by Amory Lovins in his famous article, "Energy Strategy: The Road not Taken?" A wind energy system will promote energy awareness, and, hopefully, it will act as a lure to lower consumption.

During the first phase of the study, I took a trip with John Craft and Dave Sodemann of Hays. We made stops in Kansas, South Dakota and Minnesota. We visited a number of individuals who are knowledgeable and interested in wind power, and we visited two companies which sell generators. Fred Bruns, a former employee of the Jacobs Wind Electric Company, and a long time friend of M. L. Jacobs, warmly received us on his farm near Hecla, S. D. He was glad to

answer the questions we put to him, and he provided valuable insights into the pre-REA days of wind electricity. Martin Jopp of Princeton, Minnesota was equally as helpful as Fred. It was at his shop that we first saw the new style Jacobs centrifugal governor. Our visits to the Onan Company and the Winco Company were aimed at locating a generator of current manufacture that would fit our low rpm needs. We were quite impressed with one of the Onan products, a 2-bearing, 50 hertz, 3-phase, brushless alternator, and we were also impressed with the way in which we were received by the Onan personnel.

I am currently conducting a review of literature on alternate energy systems, and I am drawing together data for making cost comparisons between competing energy sources for a specified number of kilowatt-hours per month. A market survey will soon be forthcoming, as well as an assessment of which components could be manufactured locally.

This study is to be completed and a final report made during the last part of December. Copies of the report will be available after the first of the year.

Martin Peters

## Alternatives in Shelter

### Adobe Block Experiments Continue

Being an architecture student interested in alternative architecture, I soon became involved with the Kansas adobe project while at The Land Institute.

When students Kerry Peterson and Jim Rode left The Land Institute, Giulio, Nils and I continued making traditional adobes. We abandoned use of the cement mixer as we felt mixing by hand added to the human element of the project. We used a double-brick form initially, but soon realized that we weren't satisfied with the quantity of adobes turned out daily. We again began to think of the advantages of compressed blocks: (1) stronger, more uniform blocks can be made, (2) Portland cement can be added to the mix, making a somewhat waterproof block. These are termed soil-cement blocks

and have been used successfully in regions of the U. S. where climate necessitates the use of waterproof blocks.

We experimented with several forms before a satisfactory one was built. The final form was built with 2 X 6's, hinged on three sides and latched on the fourth. (See sketch.)

Compression of the soil-cement mixture was achieved by tamping it down with a couple of heavy iron bars from the scrap pile. After the mixture was compressed in the form, we dragged the form down a ramp to where the blocks were being allowed to dry temporarily. The blocks are fragile at this point and cannot be moved to the curing stack for several hours. When curing, the blocks should be kept covered in a dark, cool place and sprinkled with water daily for the first few days. It is important to inhibit the drying process in order for the soil and cement to bond together well. The blocks should then cure for several weeks before using in construction. The quality of these blocks is comparable to that of commercially made concrete blocks.

Before the summer session ended, I had the opportunity to visit New Mexico and observe adobe architecture there. Traditional adobe construction was evident in older structures, but scarce in modern construction. Wood-framed construction seems prevalent now. These structures are merely stuccoed on the exterior for that "adobe look."

I spoke with one contractor whom I found finishing the interior of a recently constructed solar "adobe." It was actually wood-framed construction covered with stucco. This dwelling, I was informed, was to sell for over \$100,000. It was attractive, but it still couldn't compare to a well-designed, massive walled adobe dwelling.

I hope to continue researching adobe block making and construction as a means to a humanistic, low cost and less energy intensive architecture.

John Jankowski

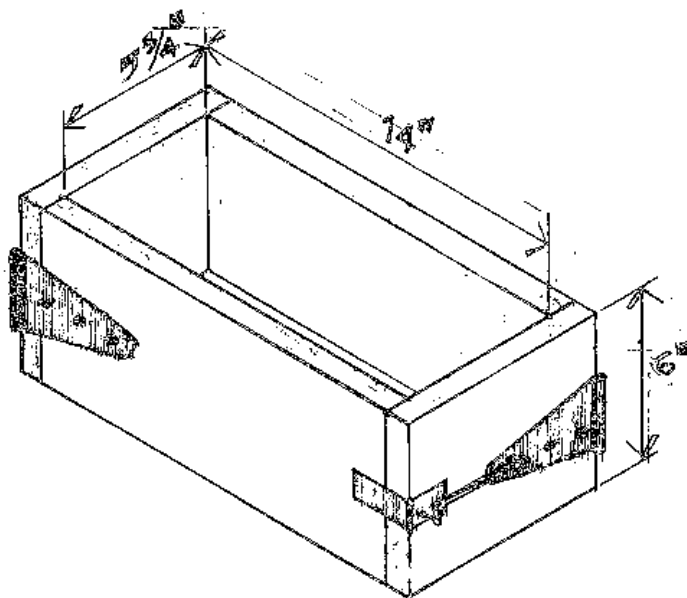

Just under fifteen tons of approximately two to two and a half inch river gravel will be used as the heat storage material. (Fifteen tons sounds like a lot, but it is just a dump truck load.) This gravel will be stored in a triangular-shaped structure in the lower story which extends up through the second story in the classroom area.

We have installed some louvered openings in the west wall to use the system in the summer for drying garden and orchard products. For this job, during the day we will simply bypass the rock storage and run the heated air directly into a cabinet with trays containing the food we wish to dry. When not drying food, the heated air will be discharged to the outside during the summer. At night, we will use the collectors and duct work to bring cool air to the rock.

On an open day in the winter, we expect to harvest around 328,000 BTU's of sunlight. We think this system will take care of 70-90% of our total space heating needs, depending on the nature of the winter.

In the next LAND REPORT we will show a diagram of the system and explain its integration into the building. We also should have some indication as to how it is working.

Wes Jackson

"We are not an insensible people, utterly brutish, concerned solely with today, and incapable of thinking about tomorrow. But we need to remind ourselves, in our quest for immediate subsistence and wealth, that while a bird in the hand is worth two in the bush, birds breed in pairs and nest in bushes."  
(from Deserts on the March by Paul B. Sears)

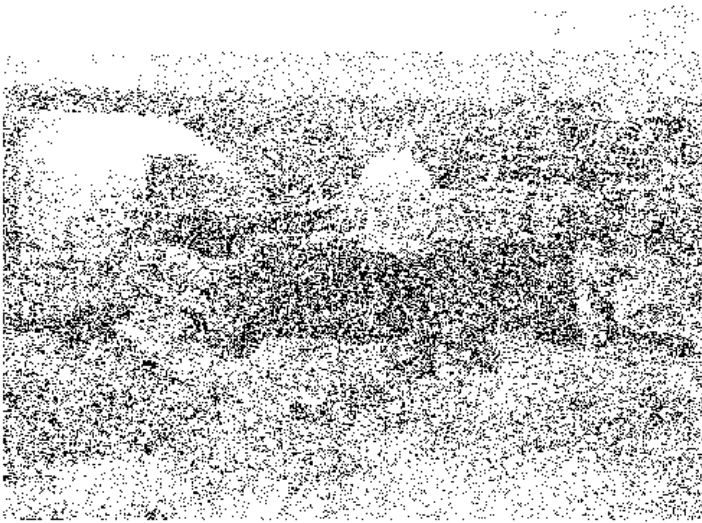

Giulio Tambalo (on left) and John Jankowski continue work on the adobe structure.

## Solar Heating in the "Doings" Building

Construction progress on the new building was slow this summer because of other priorities. However, we did insulate and sheetrock the upper floor, and we partly installed the solar heating system.

The solar collectors on the slanting south roof occupy 364 square feet. The patio doors, for which we paid \$4.50 each several months ago, are the glass coverings. Each door is four feet wide and six and a half feet high. Two layers of doors significantly increase the efficiency of heat retention.

## Special Programs at the Land

- I. TWO DISCUSSION EVENINGS on The Genesis Strategy by Stephen Schneider. (Available at Downtown News & Books, Salina, \$4.95)  
September 19 and September 22, 7:30 P. M. at The Land.  
\*REGISTRATION: \$5.00. Due by Sept. 12. Limited to 25 people.  
The Genesis Strategy is a no-nonsense evaluation of climate and of the dangerous prospect that we are drastically disrupting the world's climate system and affecting its food supply. It is a series of concrete proposals based on a principle as old as the Bible itself--namely, that we should plan for adversity by maintaining diversity and by providing ample margins of safety to keep the world alive.
- II. TWO DISCUSSION EVENINGS on Should Trees Have Standing? Toward Legal Rights for Natural Objects. (Downtown News & Books, \$1.50)  
October 25 and October 27, 7:30 P. M. at The Land.  
\*REGISTRATION: \$5.00. Due by Oct. 15. Limited to 25 people.  
This provocative little book (actually a reprint of a paper) will be discussed in conjunction with The Endangered Species Act of 1973 and an article in the May Audubon magazine, "Mighty like a Furbish louscwort."
- III. SOLAR COLLECTOR WORKSHOP FOR DO-IT-YOURSELFERS.  
Saturday, November 12, 8:30 A.M. at The Land. (Bring a sack lunch.)  
\*REGISTRATION: \$5.00. Due by Nov. 2. Limited to 25 people.  
We will build a flat plate collector in the morning. Basic information on how the collector works and general problems of solar heating systems, including both air and water storage systems, will be discussed.
- IV. LECTURE SERIES ON GREAT AMERICAN NATURALISTS. (John Muir, John James Audubon, Aldo Leopold)  
January 16, 23, and 30 at The Land, 7:30 P. M.  
\*REGISTRATION: \$5.00. Due by Jan. 6.

\*Send to Dana Jackson, The Land Institute, Rt. 3, Salina, Ks. 67401.

## How Does Our Garden Grow?

Alternatives in agriculture interest us at The Land. We hope to be developing experiments and ongoing projects in this area in the future. However, in this first year of construction and reconstruction, organization and development of The Land Institute, we have nothing to show except the Jackson family's large organic garden.

We have cultivated an organic garden on The Land during five growing seasons. The garden began on the edge of a wheat field and expanded into an area which was planted in alfalfa. Currently, we have approximately one-half acre set aside for the garden.

Preparation for the garden begins each year in January when the seed catalogues arrive. Before ordering, I make an inventory of left-over seeds, study the invoice from the previous year, and read my old garden notebooks. These notebooks record when things were planted, how well they came up, when pests first appeared, the effects of interplanting or homemade sprays on pests, and general opinions of the plant varieties used. They contain garden plan sketches and planting schedules. All this information is taken into consideration before I order seeds.

Planting begins in the house between the first and the fifteenth of March. Broccoli, cabbage, tomatoes, peppers, eggplant and marigolds are started in flats in the living room windows. By the third week of March, we begin planting the first of the hardy spring vegetables outside: beets, onions, radishes, peas, carrots, lettuce and spinach. Less hardy vegetables are not planted until May 1 or after.

An efficient watering system in the garden has made the work easier. Plastic pipe is buried in the ground down the middle of the garden, with hydrants every 20-25 feet. This diminishes the problem of dragging hoses across the plants to set soakers and sprinklers. The past summer was unusually wet, and we watered only a few times, but during the previous growing season, our watering system was essential in order to keep plants alive during July and August.

By this time of the year, the garden looks very untidy, although we use a heavy mulch between all the rows to preserve soil moisture and keep down weeds. As soon as the plants are tall enough, we mulch around the stems with straw and horse manure. In between rows we lay slices of baled straw or spoiled hay a la Ruth Stout. We use bales of wheat straw from fields of neighbors every year after harvest and stack it along the terrace. The straw works well to keep down weeds until after the vegetables are harvested. Then weeds seem to get away from us in the potato patch and the corn patch

## With Sunflowers!

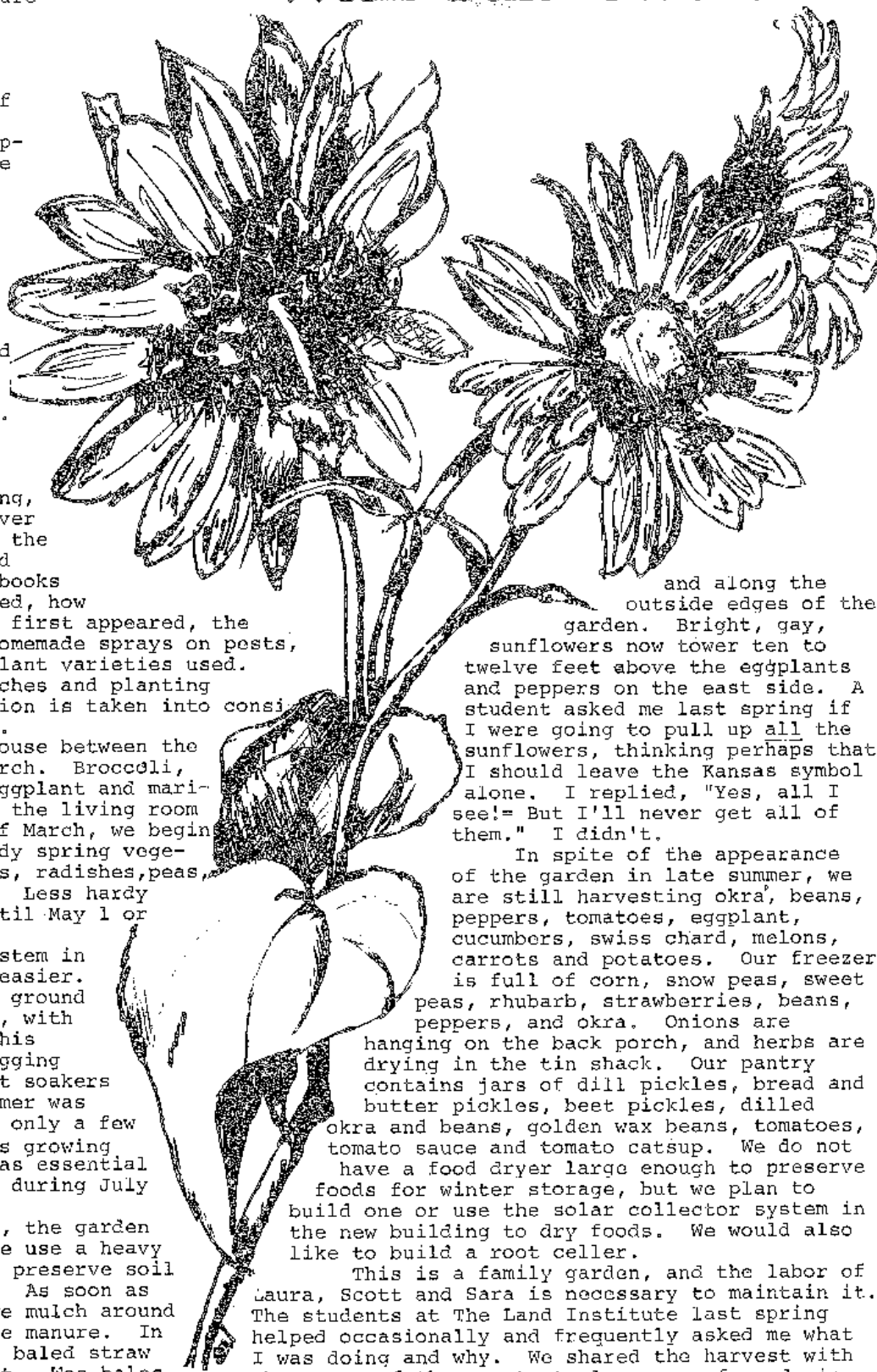

and along the outside edges of the garden. Bright, gay, sunflowers now tower ten to twelve feet above the eggplants and peppers on the east side. A student asked me last spring if I were going to pull up all the sunflowers, thinking perhaps that I should leave the Kansas symbol alone. I replied, "Yes, all I see!" But I'll never get all of them." I didn't.

In spite of the appearance of the garden in late summer, we are still harvesting okra, beans, peppers, tomatoes, eggplant, cucumbers, swiss chard, melons, carrots and potatoes. Our freezer is full of corn, snow peas, sweet peas, rhubarb, strawberries, beans, peppers, and okra. Onions are hanging on the back porch, and herbs are drying in the tin shack. Our pantry contains jars of dill pickles, bread and butter pickles, beet pickles, dilled okra and beans, golden wax beans, tomatoes, tomato sauce and tomato catsup. We do not have a food dryer large enough to preserve foods for winter storage, but we plan to build one or use the solar collector system in the new building to dry foods. We would also like to build a root cellar.

This is a family garden, and the labor of Laura, Scott and Sara is necessary to maintain it. The students at The Land Institute last spring helped occasionally and frequently asked me what I was doing and why. We shared the harvest with them, one of the greatest pleasures of gardening. Even though the garden was not a student project, it was there, and the students learned from it. Space and organic material are available for individual gardens or experiments, and we hope in the future the students will cultivate their own plots.

(cont'd. on page 9)



(contd. from page 8)

Mary Harbin was a student during the summer session who came specifically to learn about organic gardening, and she spent many hours helping me with whatever work needed to be done. An article about her experience follows.

Two students attending this fall semester have expressed an interest in planting a fall garden. With all the work of the summer garden and the hours involved in food preservation, I sometimes look forward to frost and the end of the garden, the way children look forward to the end of school. However, since we have a large stock of glass patio doors, many ideas for gardening under glass have come to mind. We will probably box in small areas and cover them with glass, or plant a pit garden. The gardening season is not over yet.

Dana Jackson

## Learning in the Organic Garden

When I arrived at The Land Institute in the middle of June, the organic garden was flourishing. Dana had planted a variety of vegetables and fruit, covering about one half acre. At the north end, the squash plants, interspersed with marigolds, were rapidly spreading their leaves, under which small yellow squash were beginning to form. The hardy potatoes were nearby and, further down, were carrots, with borders of onions along the paths. The corn, well-watered by spring rains, was tall. Farther south, eggplant, beans and okra were showing promise and a square plot of broccoli plants held small clusters of bright green. Last, but not least, melons had their place at the southern edge of the growing area. Radishes ringed each hill as barriers to the cucumber beetle.

Dana and I worked on several tasks during the summer session. Besides the continual task of weeding (Laura offered me a speed weeding course!), the two enemies with which we were most often in combat were the squash bug and the broccoli worm, or cabbage worm. Since the squash bug seems to prefer the heat of the day for moving around, we set out under the sun to pick the creatures off, one by one. They seemed to multiply faster than we could exterminate them, but we managed to keep them from destroying the plants for awhile. The cabbage butterfly lays small eggs which turn into green worms that are almost the color of the plant's leaves. After we removed these, the results were good for a few days until the butterfly appeared again to begin the process once more.

The results of our labor were well worth the effort. A meal of home-grown food is really a treat for the taste buds. I discovered that caring for a garden, picking the vegetables and preparing them properly is a great satisfaction. At the time of my departure from The Land Institute, I had begun to develop a more meaningful relationship to the earth. I look forward to further explorations of those forces which connect man and his biosphere.

Mary Harbin

## Getting Acquainted with the KOP

The Land Institute first became aware of the Kansas Organic Producers through John Vogelsberg, father of Nancy Vogelsberg, one of the first semester students. John and his other organic farming neighbors, Al Ketterer and Jack Dwercotte, took students from The Land on a tour of their farms and explained their crop rotation systems. The Land Institute became a supporting member of the KOP as a means of having more contact with experienced organic farmers and learning from them. We also hope to aid the KOP in their program of public education.

In July, Iralee Barnard, a friend of The Land and KOP member, and I attended the first annual KOP picnic at the farm of Bud Bauman near Sabetha, Kansas. We listened to board members Jim and Sue Lukens of Beloit, Raymond Meier of Lincoln, John Vogelsberg of Home City, Charles Gardiner of Topeka and Bud Bauman discuss KOP business in the morning. After the board meeting, members shared a potluck lunch along Bud's pond. The table was loaded with organically-grown vegetables and fruits, imaginatively prepared, and delicious whole grain breads. I couldn't decide if the food were really as super-lucious as it seemed, or whether the knowledge that it was all healthy food made it seem extra special. In the afternoon, the group rode on a hayrack to see Bud's field of open-pollinated corn, then toured more of the farm by car.

Farm tour meetings offer KOP members an opportunity to discuss problems and solutions related to organic methods. They also exchange information and ideas through a bi-monthly newsletter containing articles about natural fertilizers, composting, insect control and marketing opportunities.

The organization has set up standards for certifying crops as organic and are working out methods for inspection. Certification will benefit the consumer who can be assured of the honesty of the organic label. In spite of some controversy over the term "organic," the KOP would not abandon it. In the article following reprinted from the KOP Newsletter, Jim Lukens explains what really makes a product "organic."

Steve Palmer has visited various members of the KOP as our representative to explore ways in which The Land Institute could be of service to the organization. Because Salina's central location is convenient, we hope to host a KOP meeting at The Land when our building is ready.

Dana Jackson



## A Frame of Mind

What makes a product organic? Is it the fact that no dangerous chemicals have been used to protect or preserve it in storage? Is it the fact that no insecticides were used in its production? Is it the fact that no harsh chemicals were used on the soil? Or is it, rather, the producer's frame of mind, a way of looking at the world, a perspective on life and living that compels all of the above and more?

The organic farmer has an understanding of his own place in the complex system we call nature, and the need for cooperation among all members of that system. Furthermore, he knows that we are what we eat, and we eat what we feed to the soil. He views the soil, not as a sponge which will soak up water and nutrients and hold them for the plants to use, but as a complex culture, teeming with micro-life, whose health is essential to the health of the crop and the health of the eater of the crop. And he sees that crop, not only in terms of bushels or pounds or dollars, but also as food--nutritious food for someone's table.

But you can't regulate a frame of mind. You can't require an approach to life. We must not be deceived by organic standards, be they self-imposed or government imposed. They can only specify the actions, not the attitude that leads to the actions. We must base our production and handling methods, not on some set of rules, but on our love for life and health at all stages of nature's cycle of interdependency.

Jim Lukens  
(from the KOP Newsletter)

..."Bare ground left by the plow will have as much soil washed off in ten years as the unbroken prairie will lose in four thousand. Even so, soil in the prairie will be forming as fast as, or faster than it is lost."  
(from Deserts on the March by Paul Sears)

## Towards Tomorrow Fair '77

The scene was almost medieval: spilling across a rolling meadow, surrounding a placid lake, a bustling bazaar greeted me. Merchants sat at their booths, vending everything from Alchemy to Zen, while from a stage minstrels bathed the market with their song. Jugglers flashed through the crowd, amusing everyone with their antics, and a puppet theatre captivated the children. Overlooking all, in a forum atop a nearby hill, men and women of wisdom spoke to the gatherings of thousands who had made the pilgrimage to hear them. Although I perceived the scene as medieval, I was actually attending the "Toward Tomorrow Fair '77," held at the University of Massachusetts campus in Amherst this past June.

Billed as "a country fair of the future," the three day event attracted 25,000 people from across the nation, half again as many as the first fair last year. Attendees were invited to explore alternatives for a changing world, and they were provided with ample opportunities: on hand were dealers in solar-heating systems, wind-electric generators, water-conserving toilets, and much more. Also abundant were various organizations dispensing

information on such subjects as world citizenship, land trusts, and the perils of nuclear power. Appetites were amply met by a myriad of unconventional food fare, ranging from buckwheat sprouts to barbecued tofu. For those with a taste for the occult, "pyramid hats," alleged to possess mysterious powers and sharpen the minds of those who wore them, were being sold at the fair. I saw quite a few of the pointed objects floating through the carnival crowd. I tried one on myself, but the only thing I really felt was silly.

Perhaps of greatest attraction were the lectures and presentations being given throughout the fair in the university buildings. Over-capacity crowds crammed in to hear such heavyweights speak as R. Buckminster Fuller, who demonstrated magician-style his theories of geometry in Nature. Ralph Nader brandished his rhetorical sword with usual fire for consumer rights, and biologist/ecologist Barry Commoner wowed the audience with his expose of energy politics in America. Steve Baer of Zomeworks, Murray Bookchin of Goddard College, John Todd of New Alchemy Institute, and Helen and Scott Nearing were some of the other notables at the fair. Less-renowned, but equally interesting speakers, offered short courses on such diverse subjects as solar and wind energies, organic agriculture, space colonization, third world development, women's rights, acupuncture, rolfing, and so much at once that it was impossible to absorb more than a fraction of the crazy-quilt exposition for its duration.

But I tried. And on the eve of the final day, exhausted but buzzing with experience, I recognized the most valuable asset of all at the fair-- all the people who attended it. Never before had I participated in a cultural event of that magnitude, and the energy generated by the large gathering was an indicator to me of a growing awareness in American consciousness. Young and old alike, we all seemed to share in the quest for a saner, more livable world that the "Toward Tomorrow Fair '77" addressed itself to. And while the querying crowds may have caused the lecture rooms to be hot and stuffy and uncomfortable, there is, admittedly, a persevering comfort in numbers.

Mike Weiss



Mike Weiss sands wind generator blades.

# Kansans Protest



## Nuclear Power

Following the speeches and release of balloons, the demonstrators marched peacefully through Burlington. When they reached the People's National Bank, a voice over the loud-speaker system in a van decorated with official looking civil defense signs announced:

This is not a test. This is an emergency announcement from the Coffee County Office of Civil Defense. Thirty minutes ago the Wolf Creek Nuclear Power Plant had a major accident. A large amount of radiation escaped into the air...We do not wish to alarm you, but based on current wind direction and velocities, we now have ten minutes before the lethal radiation reaches us. Please remain calm.

Upon completion of the message, and after ten minutes had elapsed, the demonstrators fell to the sidewalk, staging a "die-in" in front of the bank. Other protestors in white uniforms placed tombstone-shaped signs with the radiation warning signal on the "bodies." After an interval of taps, the demonstrators returned to the gathering site.

Wes Jackson of The Land Institute spoke to the crowd following the march and "die-in." "We energy junkies are currently eight per cent addicted to nuclear power. We can cut out that eight per cent now and turn our backs on nuclear power forever. When we are thirty per cent hooked, cold turkey withdrawal symptoms may be more than we can stand."

Jackson reminded the protestors that the federal government had once planned to deposit nuclear wastes in salt mines near Lyons, Kansas, but had abandoned these plans due to the opposition of Kansans and tests which showed the site to be inadequate. He warned them that salt mines near Ellsworth might still be under consideration, and if Kansans have their own nuclear plant, they have no moral grounds to stand on if the government pursues the development of storage facilities in Ellsworth. "We can't tell the government to keep nuclear garbage out of Kansas if we are producing nuclear garbage of our own."

Jackson also urged the audience not to rely entirely on economic arguments against nuclear power. "What if we discover, when the full costs of land reclamation after coal mining are in, that nuclear power is cheaper?" He stressed that the moral arguments against nuclear power should be kept in the public's mind.

The Land Institute was well represented at the demonstration by Giulio and Mary Ann Tambalo, Cindy Jones, Mike Weis, Sue Leikam, Nancy Vogelsberg, John and Carol Craft, Marty Peters and Wes and Dana Jackson. Many friends of The Land from around the state were also participants.

On August 6, approximately 150 Kansans demonstrated in Burlington, Kansas, against the construction of the Wolf Creek Nuclear Generating Plant by Kansas Gas and Electric and Kansas City Power and Light Co. The dangers of radioactive fallout were emphasized by the release of hundreds of balloons, each tagged with a message warning the reader that radioactivity could reach him as easily as the balloon in case of an accident at Wolf Creek. On this same day, the 32nd anniversary of the atomic bombing of Hiroshima, balloons were released by demonstrators at Seabrook, New Hampshire, Oak Ridge, Tennessee, and several other nuclear plant sites in the U. S.

The Wolf Creek Nuclear Generating Plant received a license for construction by the Nuclear Regulatory Commission this spring, in spite of efforts by opponents of nuclear power. Wolf Creek Nuclear Opposition, Inc. and Kansas City People's Energy Project, organizations which sponsored the peaceful demonstration on August 6, and Mid-America Coalition for Energy Alternatives have promised to continue the fight to stop construction.

In a speech at the rally, Senator John Simpson, a member of the Board of Directors of The Land Institute, and an outspoken opponent of nuclear power in the state legislature, told the crowd that the Wolf Creek Plant "looms as a grim reminder of mistakes and miscalculations by those who seek short term gains at the expense of the future...The nuclear age is not a legacy we can leave for our children, grandchildren and great grandchildren."

Senator Simpson urged listeners to persist in efforts to convince Kansans to abandon the development of nuclear power. "And yes, we must renew our efforts to convince K. G. & E. and K. C. Power and Light, even though it appears they have their feet planted in concrete, their corporate heads in the sand, and are racing headlong into economic disaster. Unfortunately, their economic misfortune will be the albatross tied around the neck of all Kansans. Imagine what it will mean if Wolf Creek stands idle in 1995."

To protect Kansans from the errors of the utility companies, the Kansas legislature should pass three laws, Simpson stated. 1. Provide that no nuclear plant can be built until the federal government has certified that fuel reprocessing plants have been developed. 2. Provide that no nuclear plant can be fueled until it has been certified that adequately tested nuclear waste disposal facilities are operational. 3. Amend the electric plant siting law so that no nuclear plant not already in operation can be operated without direct approval by the legislature.

## Friends of The Land

During the first year of our existence, a loosely knit group of helpful people began to be known as the "friends of The Land." This group included those who encouraged the initial organization of The Land Institute, and those who gave us materials or tips about free or cheap supplies during the construction of our first "Doings" building.

The friends of The Land became extremely important after a fire destroyed the shop, classroom and library. From raking out the debris and hauling it to the dump, through the beginning of new construction, the friends of The Land were involved. The two-day "log raising" was an unforgettable experience of community.

Friends of The Land from all over the United States have also been involved, especially in the process of rebuilding the library. The individuals in this network of friends believe that a search for alternatives in agriculture, energy, shelter and waste, and a search for alternative thinking to fit the technology, is a valuable effort.

Because of this history of support, the Board of Directors felt that The Land Institute should give these many friends an opportunity to contribute in a financial way. Contributors will formally become Friends of The Land. They will receive THE LAND REPORT and any other publications of The Land Institute and will be invited to a meeting and special field day at The Land each year. The Land Institute is a non-profit organization, and all gifts are tax deductible.

Name \_\_\_\_\_

Address \_\_\_\_\_  
\_\_\_\_\_

Phone \_\_\_\_\_

(CHECK CATEGORY OF CONTRIBUTION)

\_\_\_\_\_ \$10                      \_\_\_\_\_ \$25                      \_\_\_\_\_ \$50  
\_\_\_\_\_ \$100                      \_\_\_\_\_ \$475 (student sponsor)  
\_\_\_\_\_ \$3 Subscription to THE LAND REPORT only.

## University for Man Class at The Land

On October 8, the University for Man from Manhattan is offering a class at The Land. You are welcome to attend. If you have never visited The Land before, but have been wishing to visit, we recommend that you come on that day. Activities are planned from 10:30 A.M. until 3:00 P. M. Bring a sack lunch.

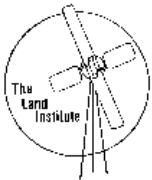

**The Land Institute**  
Rt. 3  
Salina, KS 67401

Non Profit Org.  
U. S. Postage Paid  
Permit No. 81  
Salina, Ks. 67401