

Number 7

THE LAND REPORT

Spring 1979

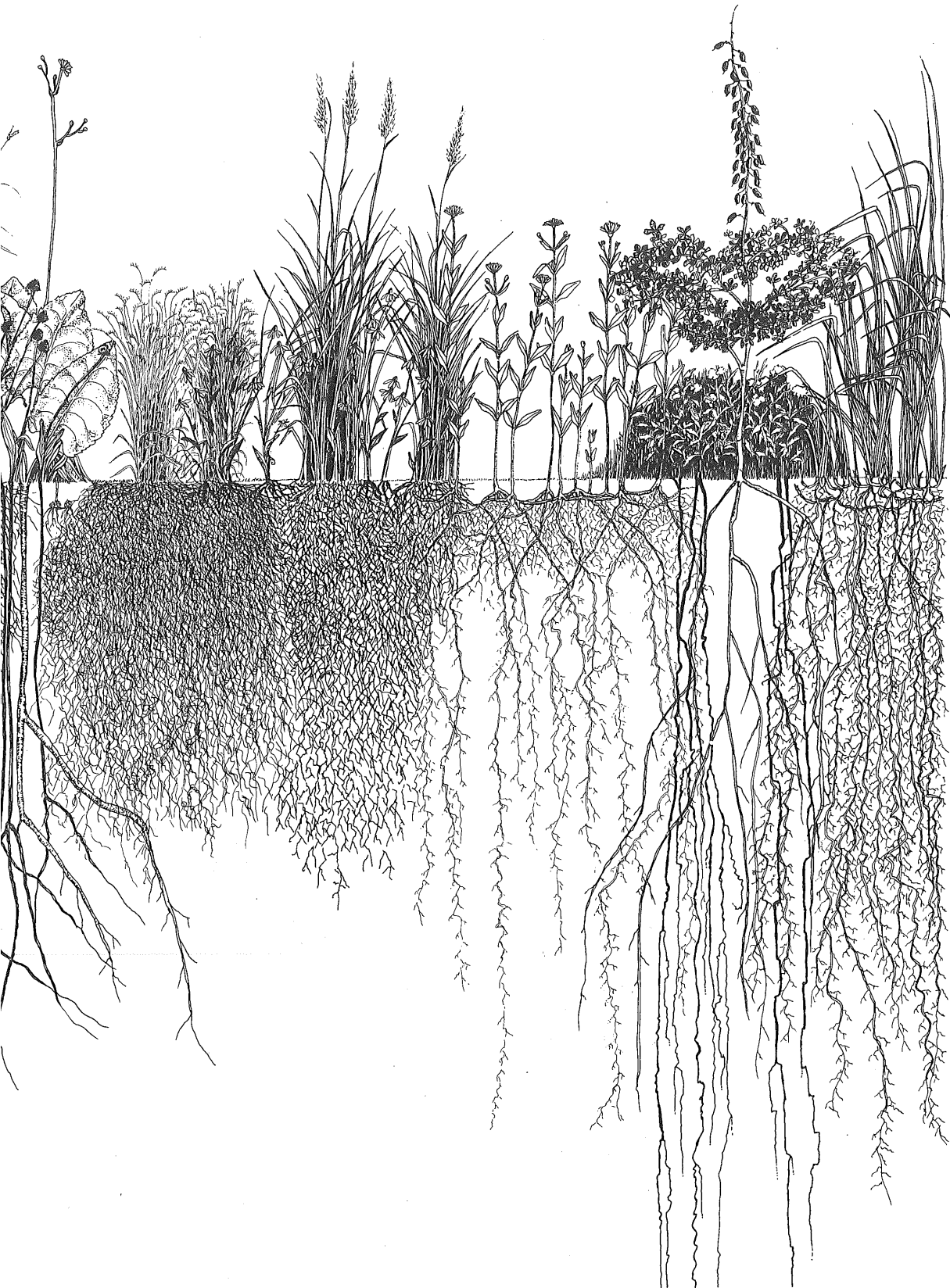

9'
8'
7'
6'
5'
4'
3'
2'
1'
0'
1'
2'
3'
4'
5'
6'
7'
8'
9'

10' 11' 12' 13' 14' 15' 16' 17' 18' 19' 20' 21' 10'

Contents

<u>AT THE LAND...</u>	
Summer Energy Course Offered.....	2
Grant Received	2
The Archdruid to be at The Land.....	3
Friends of The Land meet Friends of the Earth..	3
Prairie Roots/Human Roots.....	4
<u>ALTERNATIVES IN AGRICULTURE</u>	
Perennial Crop Research Underway.....	5
The Need for a Compact Elephant.....	6
Shelterbelt Study.....	7
The Grow-Hole as a Fall Greenhouse.....	8
The Green Thumb Gathering.....	9
<u>ALTERNATIVES IN ENERGY</u>	
The Status of Wind Energy at The Land.....	10
KP&L, Kansas' Largest Utility.....	12
Windmilling Wheat.....	13
Women's Sun Day Energy Conference Held.....	14
Civil Disobedience vs. Uncivil Obedience.....	15
The Soft vs. Hard Agricultural Path.....	16
<u>THE ALTERNATIVES NETWORK</u>	
The New Alchemists.....	19
The Village as a Solar Ecology.....	19
Max's Pot.....	21
Audubon Wild Flower Book Published.....	21
Prairieland Food Cooperative.....	22
Half Asleep Near the Three Rivers.....	22
a poem by Harley Elliott	
<u>ALTERNATIVES IN SHELTER</u>	
Indian House has New Roof.....	23
<u>ALTERNATIVES IN WASTE DISPOSAL</u>	
Barrel Composting Toilet Installed.....	24
Visitor Policy....Calendar....Fall Term.....	25
<u>PRESERVING THE TALLGRASS PRAIRIE ISLAND.....</u>	26

At The Land ...

Summer Energy Course Offered

Four hours of graduate or undergraduate credit from Emporia State University can be earned for the energy course, "OUR ENERGY FUTURE: Soft Paths vs. Hard Paths," to be offered at The Land June 4-29. Dr. Charles A. Washburn, Professor of Mechanical Engineering at California State University, Sacramento, will be the principal instructor during the morning lecture-discussion period, and a broad spectrum of energy topics will be covered.

During the afternoon, each student can work on two projects, one solar and the other wind-electric. Nelson Kilmer, Associate Dean at Hesston College and partner in a company manufacturing solar collectors, will supervise the construction of small collectors either for space or hot water heating. Supervising the construction of individual twelve-volt wind electric systems will be John Craft, formerly an associate at The Land and now a high school science teacher. Mr. Craft has had direct experience with numerous types of wind generators and has constructed home-built systems out of old automobile parts.

The tuition is \$27/credit hour (\$108) for graduates, \$18 credit/hour (\$72) for undergraduates. Materials costs and salaries for technical instructors are an additional \$210, making a total of \$318 for graduates and \$282 for undergraduates.

All tools and materials will be provided, except each student should have his or her own hammer, screwdriver, measuring tape and textbooks. Housing accommodations are available on the Kansas Wesleyan campus for \$5-\$15 a week.

There are still a few openings for this course (enrollment is limited to 24). Call Wes Jackson (823-8967) for more information.

Grant Received

The Board of Directors of the Jessie Smith Noyes Foundation has approved a grant of \$10,000 to The Land Institute for the academic year 1979-80. In making this grant, the Foundation "hopes to increase the number of people knowledgeable in the elements of sustainability essential to restoring and maintaining a balanced ecosystem."

The grant will be used to provide tuition and stipends for undergraduate and graduate students who have a demonstrated interest in environmental problems.

Annual Meeting of the Board of Directors

1:30 P.M. Saturday, June 3, at The Land.



The Land Report

is published three times a year by

The Land Institute
Rt. 3
Salina, Kansas 67401

Editor.....Dana Jackson
Ed. Asst.....Sharon Forster
Photography.....Terry Evans & Carol Maguire
Proof-reader....Isabel Mason
Printer.....Arrow Printing Co., Inc.

Contributing to this issue: Marty Bender,
Pat Dreese, Harley Elliott, Jeanne Green,
Charles Grimwood, Alissa Guyer, Dana
Jackson, Wes Jackson, Carol Maguire, and
Brian Williams.

SUBSCRIPTION RATE: \$3.00

The Land Institute is a non-profit
educational-research organization
devoted to a search for alternatives
in agriculture, energy, shelter and waste.

BOARD OF DIRECTORS: Frank Anderson, Karen
Black, Steve Burr, Sam Evans, Bernd Foerster,
Dana Jackson, Wes Jackson, Gordon Maxwell,
Nancy Miller, Wendell Nickell, John Simpson,
John Schwartz.

HONORARY: E. F. Schumacher (1911-1977)
Amory B. Lovins

The Archdruid to be at The Land

David Brower, President of Friends of the Earth, will be a special guest of The Land Institute on June 2 and 3. He will participate in the discussion about the relationship of man and the prairie on Saturday night at the Evans Ranch. On Sunday, members of Friends of the Earth and Friends of The Land will have an opportunity to meet this famous environmentalist-humanist at a picnic and spring festival from 10:30 A.M. until 3:00 P.M. at The Land.

For 38 years David Brower has been a leader in the conservation movement. In 1941 he was elected to the Board of the Sierra Club, and in 1952 he became its first Executive Director, a position he held until May, 1969, when he resigned and founded Friends of the Earth, an international, politically active conservation organization. While leading the Sierra Club, he was active in several major national park campaigns: establishing Kings Canyon National Park, preventing relinquishment of timberlands from Olympic National Park, and the establishing of Redwood National Park and the Point Reyes National Seashore.

"The Earth's Wild Places," award-winning books published by Friends of the Earth, follow the Exhibit Format Series David Brower conceived for the Sierra Club in 1960. He established the design standards and was general editor of the twenty Exhibit Format Series volumes as well as all "The Earth's Wild Places," eight to date.

David Brower has climbed every peak in the Sierras higher than 14,000 feet and has received credit for 33 first ascents. During his three years of military service, he prepared manuals and led mountaineering classes in Colorado and West Virginia. He saw combat in Italy with the U. S. 10th Mountain Division and was awarded the Combat Infantryman's Badge and the Bronze Star. From 1939 to 1956 he led in and expanded the

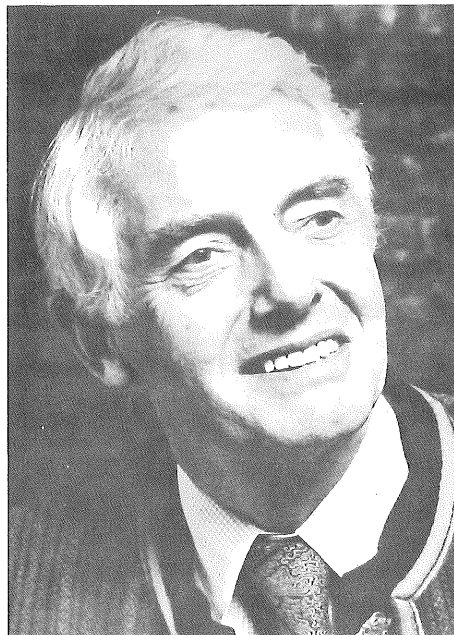

Sierra Club Wilderness Outings Program, establishing knapsack and river trips and leading some 4,000 people in that period on prolonged trips into remote wilderness.

David Brower has received a long list of awards for his work in conservation, and a long list of degrees, including a Doctor of Humane Letters from the Starr King School for the Ministry, Berkeley, California. The citation from Starr King was written by Garrett Hardin, and refers to the biography of David Brower by John McPhee, Encounters with the Archdruid.

"David R. Brower--charismatic leader of crusades for the liberation of the temple of nature from its oppressors, archbishop of the church of the wilderness; archdeacon of the cathedral of the environment; archenemy of all who would sell our heritage in nature for a mess of pottage; and, by universal and unchallenged acclaim, the first, the greatest, and indeed the only archdruid."

Friends of The Land Meet Friends of The Earth

All Friends of The Land, subscribers to The Land Report, and members of Friends of the Earth are invited to bring a picnic lunch, musical instruments, frisbies, etc., and good weather to The Land on Sunday, June 3, and celebrate together from 10:30 until 3:00 P.M.

The Friends of the Earth will be represented not only by David Brower, but also by Amory Lovins, from the British F.O.E. office in London. Lovins, an internationally-esteemed energy scholar, first visited The Land in October, 1978, to participate in the energy conference co-sponsored by the League of Women Voters and The Land Institute. He is an honorary member of the Board of Directors

of The Land Institute and will attend their annual meeting on June 2.

"OUR ENERGY FUTURE: Soft Paths vs. Hard Paths," the energy course described on the opposite page, will begin with an introductory lecture by Amory Lovins. Originally, Lovins was scheduled to present that lecture on Monday, June 4, but in order for him to be on the east coast to receive an honorary degree on Monday, this opening lecture will be delivered Sunday afternoon at approximately 2:00 P.M. Friends at the picnic will have the opportunity to hear the lecture with energy course students if they wish.

Prairie Roots/Human Roots

A look at the prairie as the ground of our culture and agriculture.

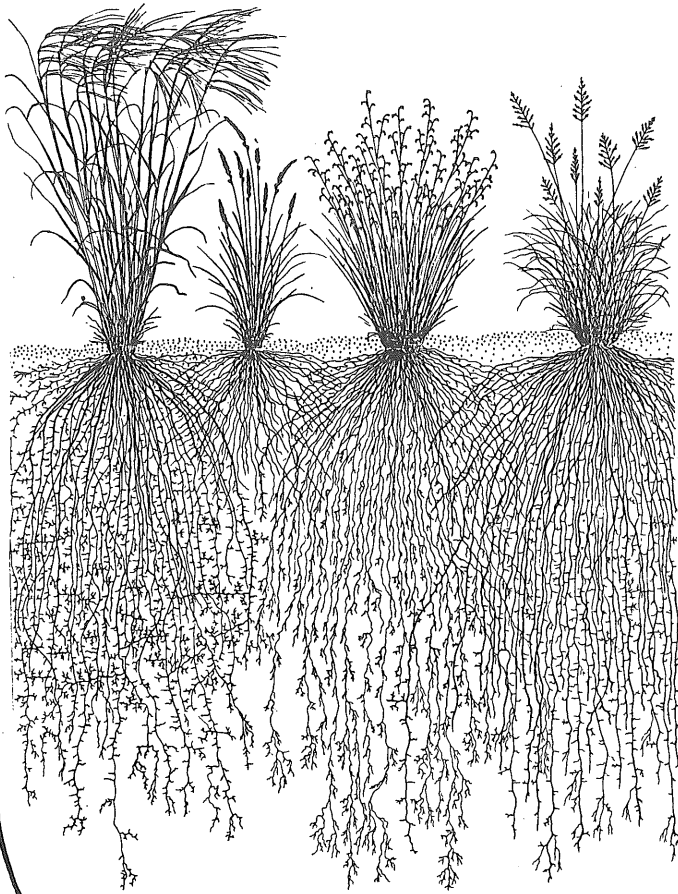

The Land Institute and the Kansas Committee for the Humanities will present a special program about the prairie on June 2 at the Evans Ranch, seven miles north of Salina on old highway 81.

"How has the prairie shaped us? How has the prairie experience forged a special sense of place in the human imagination?"

These questions will be explored through the media of poetry, photography and conversation. Everyone is invited to attend, and there is no admission charge.

Program and Participants

- 4:30 Poets Harley Elliott and Stephen Hind will read their works. George Chlebak will introduce and discuss an exhibit of prairie photographs by Terry Evans.
- 5:45 A light supper will be served (Fee \$2.50, call 823-8967 or 823-2544 for reservations) or you may bring a picnic supper).
- 7:30 Presentations and conversation concerning the prairie connection by David Brower, O. S. Fent, Wes Jackson, Richard Keller, Keith Sebelius and David Wishart.

The evening will conclude with an extraordinary slide show created and prepared by Robert Regier

Jim Peterson and Terry Evans are directors of this prairie project. During the summer they will take the exhibit, slide show and taped portions of the discussions and poetry readings to several Kansas towns for presentation.

SPRING SEMESTER STUDENTS TAKE DISCUSSIONS OUTSIDE

(left to right)

Jeanne Green, Salina.
Brian Williams, Nashville,
Tennessee.
Jim Peterson (Research
Associate, Salina).
Karl Zimmerer, Antioch
College, Yellow Spgs.,
Ohio.
Wendell Wiebe, Hesston
College, Hesston, Ks.
Curtis Carroll, Custer,
South Dakota.
Wes Jackson
Ron Mueller, Versailles,
Missouri.
Marty Bender (Research
Associate, Dayton,
Ohio).
Alissa Guyer, Stanford
Univ., Palo Alto, Ca.



Alternatives in Agriculture

Perennial Crop Research Underway

In past Land Reports we have stressed that soil loss is dramatically associated with the monoculture of annuals. Such mechanical devices as ponds and terraces, while they do slow erosion, are not nearly adequate enough, and soil continues its trip to the sea at an unforgivable rate.

Annual monoculture has been condemned because of the high energy demands of pesticides and fertilizers and their poisonous effects in the environment. We can add to our list of problems the failure of engineering to effectively control soil loss. In order to change the agricultural system to eliminate or reduce these harmful effects, we must consider a biological approach.

The native prairies retain most of their soil capital and high species diversity. They run totally on sunshine, and the species diversity prevents pests from occurring in epidemic proportions. The collective seeds of the prairie are of a low yield on a per acre basis. Leaf protein is more plentiful. We can eat the meat of a grass-eating herbivore raised on these prairies, but tradition, and maybe our evolution, prevents us from grazing on leaves to any large extent. We think it is possible to increase the seed yields of various perennials and to grow and harvest them in polyculture. But first we need to find a combination of perennials which would give greater seed yield in a polyculture than in separate monoculture. The following is a description of these experiments now underway or shortly to begin at The Land.

Experimental Design

Our original plan was to carry out four simultaneous experiments, each one involving six perennial species of grasses and legumes represented by thirty individuals each, 180 individuals all together, positioned at random, plus enough plants to make two guard rows all the way around the rectangle. For purposes of comparison, each of these species in the polyculture would be represented by thirty plants in a monoculture with the same spacing and two guard rows all the way around. We can then compare seed productivity both in the monoculture and polycultures. We planned for our first polyculture experiment to consist of six species which would all set seed in mid-summer. Our second polyculture would set seed in the fall. The third experiment would have three species whose seeds ripen in the summer and three in the fall, a bimodal harvest. In this polyculture would be one legume and five grasses. The fourth experiment would also have a bimodal harvest of two

legumes and four grasses.

Besides selecting species based on seed-set time and yield, we also paid attention to what horizon the roots would penetrate and actively compete in. We did not want all "sod-forming" species, nor did we want all "bunch grasses." We wanted to be sure at least one nitrogen-fixing legume was in each experiment.

Our design called for each of the polyculture experiments to be replicated four times. A total of nearly 7,000 plants, 7,000 cups, was needed if we were to run all four of these experiments. During March we planted the 7,000 cups and labeled each species by color-coding ice cream sticks. All the students helped at one time or another with this enormous task. The students most associated with the project included Marty Bender, Karl Zimmerer, Brian Williams and Wendell Wiebe. Other students who spent scores of hours sterilizing soil, filling pots, painting the ice cream bar sticks, sowing seeds, manufacturing cold frames out of 3" X 12" bridge planks and patio doors, watering, weeding, and transplanting to the experimental garden included Alissa Guyer, Curtis Carroll, Ron Mueller, Jim Peterson, Jeanne Green and Jay Burns.

Part of our experimental design had emerged as we tried to imagine the conditions of harvest in the future. To make one machine trip through the domestic grain-producing meadow or domestic prairie of the future seemed desirable for energy-saving purposes. However, it might not prove practical in all cases to have either all early or all late species become ripe at once. In such a case, we must be careful that no fall-maturing species are flowering at the time we harvest the early species. When we checked flowering and seed set dates of numerous species, this proved to be much less of a problem than we had anticipated. Most grass seeds become mature six weeks after flowering, and most of the early versus late species are more than six weeks apart in seed maturity.

One problem developed when we tried to generate our random distribution of the 180 plants (thirty individuals for each of the six species) in our polyculture. This called for a random sample without replacement, but none of our statistics books had a table that would apply to our situation. A few days later, Dana Townsend, a graduate student in biology at Kansas State, who was here with a group from the University for Man in Manhattan, learned about our problem. In a week she had mailed to us several computerized printouts of random number tables generated to meet our conditions.

We expect all of the four experiments in our design eventually to be represented in the field. Poor or slow germination so far, however, has forced us to be satisfied with only one for the time being. This experiment includes Sideoats Grama, Tall Wheatgrass, Crested Wheatgrass, Intermediate Wheatgrass and its variety trichophorum, and a legume, Birdsfoot Trefoil.

We hope we have taken the first step, however modest, toward the development of a high-yielding, seed-producing, sustainable agriculture.

Wes Jackson and Marty Bender

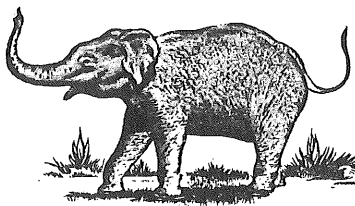

The Need for a Compact Elephant

The best personal transport vehicle man has ever possessed - where only short ranges are concerned and the weather is good - is the horse. It is self-steering, self-reproducing, never goes out of style - and only a double-decker bus gives a comparable view of the scenery. ...The horse may not turn out to be the best choice in the long run; something like a compact elephant might be preferable, because of its dexterity.

Arthur C. Clarke
Profiles of the Future

Clarke might have continued that since an elephant can stand on its head, we might strap on a strong cone which would become a hole-maker when our elephant goes "bottom up." (Such an elephant would be a solar post hole digger.) Furthermore, not only is such a creature useful for traction, lifting and tree planting, but part replacement is accomplished by ordinary cell division. A pregnant elephant, even while standing still or lying down is into manufacturing! There is no such thing as an idle pregnant elephant. These several virtues, all in one creature, involve an important principle for our coming age of sustainability.

Two opposite trends. Humans in the modern world have sought to increase production through an increased sophistication of the technological hardware and an "improvement" of their domesticated animals and plants. The improvement in hardware has led to more and more automation, and less human involvement in specific tasks. The plants and animals, however, have become less automated - more dependent upon us. Herdspersons increasingly become midwives and agriculturists must supply more energy or attention to crops. We have managed the increased involvement with our plants and animals by employing some of the hardware in the

agricultural enterprise and of course, more energy. For example, hundreds of feedlot cattle can now be fed twice a day by one farmer, though we should not ignore the tremendous support system for this one farmer. But why should these two opposite trends manifest themselves on the same planet under the direction of the same species?

An examination of the history of technology compared to the history of our plants and animals might provide a clue. Our hardware was developed in an era where first law efficiencies are of primary importance and high thermal levels possible. Engine or lighting efficiency, judged by how much energy is required for so much work or candle power, is uppermost in the mind of the engineer. Furthermore, most of this technology happened when high thermal levels were possible and gave a significant increase in options to equipment designers.

The ancestors of our plants and animals, on the other hand, arose in a very different system. First law efficiencies are rather unimportant, especially on the energy-capture side. Photosynthesis efficiency is only around 1-2 percent. During certain phases of growth, efficiency might approach 20 percent or so, suggesting plants could do better than they do now as solar collectors. Thermal levels are low in life forms. A chicken laying an egg probably even avoids a fever. For the biotic world, energy is not the limiting factor most of the time so much as water, warm enough temperatures, and nutrients.

The living world can get by with several low first law efficiencies, perhaps because most organisms have something to offer other life forms at several trophic levels. In a balanced ecosystem scarcely any organic material goes to waste. The American Bison, when alive, provided meals for numerous insects, worms, and microscopic organisms. At death the nutrients returned to the prairie as energy was extracted by the decomposers and such large animals as buzzards and coyotes. For the

living world, efficiency based on the second law of thermodynamics (doing the job with the right organism) is very important in almost all cases. Waste, from the point of view of an ecosystem, occurs when nutrients are either lost downstream or stored in matter called fossil fuel. Even a prairie fire which robs millions of organisms of billions of meals may not be waste. Soil nutrients remain bound and most soil moisture is retained. The nitrogen lost to the air is quickly regained with the increased profusion of legume growth following the fire. The prairie probably evolved to invite fire.

Implications for agriculture. The American Bison in life and death, at some time or another, is a focal point for organisms of various trophic levels. It seems to follow that if we should try to more closely approximate nature in order to develop sustainable agricultural ecosystems, we must expect a larger number of roles from our domesticates, instead of "record-setting" for one characteristic. Our plant and animal breeding programs can easily change their emphasis to accommodate the new goals.

Cattle should be useful for draft, meat and milk production. Individual species of plants would have several roles - seed, fiber and perhaps a root crop. Finally, some of these additional roles should include resource conservation. For example, it has been determined that 85 percent of all biomass on the prairie is below the surface. Looked at one way, 85 percent of the total stored sunlight in plants is allocated to soil and water conservation. Mature ecosystems accomplish this task mostly with perennials.

All this brings us back to our compact elephant. The elephant combines more potential than most any animal imaginable. It seems as humorous to expect animal breeders to immediately rush into elephant breeding as to expect plant breeders to seriously start work on the development of perennial seed-producing grasses and legumes for human consumption. Nevertheless, a serious commitment to a Soft Agricultural Path which meshes with the Soft Energy Path of Amory Lovins (see figure by Marty Bender) requires that we completely reassess the "production only" paradigm in favor of a paradigm of sustainability. Are we too impatient and unwise to allocate 50 years to this task of transition? The cathedrals built to the glory of God were hundreds of years in the making. Should not our plants and animals glorify the earth rather than serve as our instruments of destruction? Is it not time to make our plants and animals a bit less human-dependent and our physical hardware a bit less automated?

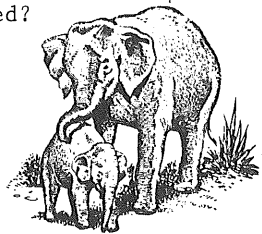

Wes Jackson

Shelterbelt Study

Because The Land Institute is working toward the development of a sustainable agriculture, we have begun to examine shelterbelts and their role in the Great Plains. A shelterbelt is a "linear woodlot" of six to twenty-four rows consisting of a diversity of trees and is planted across open farmland. Their existence serves man greatly by reducing wind erosion of the soil, supplying wood for fuel, and providing food and shelter for wildlife.

President Franklin Roosevelt began the shelterbelt program in 1935 in the hope that it would decrease the amount of soil being lost during the Dust Bowl era. Close to two hundred million trees and shrubs were planted between 1935 and 1942 in an area stretching south down to the Texas panhandle and north to the Canadian border, and eight hundred miles east-west from the Missouri River Valley to the Rocky Mountains.

Presently, although a lot of farmstead windbreaks are being planted to protect livestock and homes, field shelterbelts are on the decline, either because of deterioration due to old age or because of removal so that more crops can be raised. The removal of shelterbelts now may seem economically advantageous, but in a time of severe drought, shelterbelts may be the only source of protection against wind erosion.

It may be possible that the net annual biomass (wood) production of shelterbelts might be high enough to make shelterbelts economically competitive with crops, thus encouraging the planting of shelterbelts. As Marty Bender built up our bibliography on shelterbelts, we found that this possibility had not been researched. So Wendell Wiebe, Brian Williams, and Marty planned the layout of a contour woodlot as a demonstration of biomass production.



Wendell Wiebe digs irrigation ditch for shelterbelt with hoe he brought from India.

Consisting of four rows, each containing 100 trees, it is located on the contour of a 1,000 foot terrace to take advantage of the topsoil that was bulldozed there to make the terrace. The trees that we were able to obtain from the state and extension forestry service at Kansas State University are honey locust, black walnut, hackberry, green ash, and Austrian pine. For future research we hope to determine the net annual biomass production of shelterbelts and woodlots by making measurements over many years of tree height and diameter.

Brian Williams and Marty Bender

The Grow-Hole as a Fall Greenhouse

Michele Adam's project in the spring semester, 1978, was to germinate plants and harden them off in the growhole before the spring growing season so they would have a head start. I decided to experiment with the growhole during the fall semester of 1978 to learn how plants would cope with a gradual temperature decrease instead of an increase as tested before.

The growhole was originally a shelter designed by John Jankowski and Cindy Jones in the spring of 1977. The ten by twelve foot room is below ground five and a half feet. The walls are built out of pasture rock and cement. Above ground the walls are made from various mixtures of adobe, two bricks thick and two and one half feet high. Last spring, Michele built a door on the west side and a roof with four glass patio doors to produce a greenhouse effect. She also placed twelve 55 gallon drums full of water and painted black on pallets on the bottom of the hole to absorb heat. The water in the barrels took longer to warm up in the spring than she had hoped, and when warm weather finally came, the growhole was too warm and not properly ventilated. (The Land Report, number 5).



Carol Maguire watering the herbs.

With cool weather coming quickly last fall, I realized that for young plants to survive, the growhole would need better ventilation in the few warm weeks that were left and better insulation from the cold. The barrels still contained odoriferous, decomposing pizza sauce thinly diluted in the water, but the smell disappeared in a few days after I dug through the adobe wall on the south and installed a louvered vent directly under the extending roof. This provided the needed ventilation to cool the room during the daytime also. With the help of Brian Williams and Pat Dreese, four more patio doors were added to the first layer with strips of foam rubber in between layers. The double thickness of glass made quite a difference in heat collection of the barrels and in insulation from the cold November and December days with no sun. I also stuffed all cracks I could see with straw.

Deciding what to plant in the growhole was not difficult. As I am intrigued with the exceptional culinary and medicinal value of herbs, and have read how they are often cultivated in kitchen windows, I decided to cultivate herbs. Seeds were not available in Salina, but I found several basic culinary varieties in Dale Anderson's HERB PATCH in Manhattan, Kansas, and also ordered medicinal herbs from companies which had replied to my requests for catalogues.

On Saturday, Sept. 23, Autumn Equinox by coincidence, I planted my seeds in a soil mixture of one part sand, one part peat moss, and one part garden soil (sterilized), as suggested by Organic Gardening under Glass by George and Katy Abraham. This makes a good soil with drainage that will prevent salt build-up and fungus disease common to greenhouse plants.

The seeds were germinated in the Doings Building. After about three weeks they were two inches high, and I transplanted them to larger boxes, six inches deep and three feet long by two feet wide in the growhole. Temperatures were ranging from 68° to 80°F inside on sunny afternoons, and the plants were doing well. Then the crickets moved in. They began to use the herbs as food and the warm adobe walls as a shelter from the nippy night temperatures. Hedge apples are supposed to be nature's mothballs. They may be effective in getting moths, but the crickets liked them just as well as Rotenone, an organic pesticide which I dusted on everything. Finally, to save what few plants that the crickets didn't like, I made a small tent-like structure from plastic bags for the flat on the west wall and screen tents for the other two flats. This seemed to keep the crickets out.

October's temperatures were beginning to vary more extremely, sometimes with a thirty degree difference between the inside and the outside of the growhole. The chirping sound finally ceased by October 21, and the tents were removed to allow the plants more room to stretch their leaves.

Although I had been warned by Michele, and she had been warned by Marilyn Jones, that seeds do not germinate well in the grow hole because of temperature extremes, I did plant a number of medicinal herbs, such as pennyroyal, hyssop and horehound, on October 19. Only a few came up.

Another disappointment was that the barrels did not hold the heat as well as expected. The first measurements were taken October 2, when the water was 72°F. By November 21, the water temperature was 38°F. On that day it was 34°F inside the growhole and 25°F outside. The room temperature must have fallen considerably that night, because the next morning I found nearly everything frozen.

The growhole did not prove to be a successful greenhouse for extending the growing season. To try it again, I would recommend several design changes. First, the grass roof needs to be tilted more so that the sun reaches a larger area inside. The ceiling height of the room should probably be lowered, also, and certainly covered at night with some insulating material. Perhaps an additional heat source could be supplied through light bulbs turned on by the wind generator in the Experimental Village.

I learned much about herbs while working on this project. Some of the more common, such as basil and chervil, were familiar to me as culinary herbs. But many of the medicinal herbs, such as wormwood, rue and horehound were not as well known. Testimonies and recipes for herb preparations to relieve sore throats and coughs, and even to ward away evil spirits can be found in literature from medieval times to the current popular Foxfire series. An obvious mixture of truth and myth abounds in what is written about herbs. For interesting reading about herbs, for obtaining seeds, and to learn about cultivation and harvesting herbs, consult the list of references which follows.

Companies (Out of State)

1. Casa Yerba
Star Route 2 - Box 21
Days Creek, Oregon 97429
2. Indiana Botanical Gardens
Hammond, Indiana 46325
3. The Redwood City Seed Company
P.O. Box 361
Redwood City, California 94064

Carol Maguire

Companies (Kansas)

1. The Herb Patch
Box 146B
St. George, Kansas 66535
2. Herb Patch
Manhattan, Kansas 66502

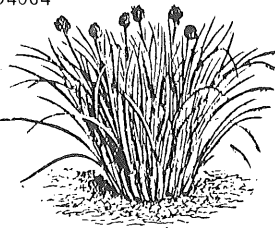

Books

1. Hylton, William H., ed., The Rodale Herb Book, Rodale Press Book Division, 1974
2. McCleod, Dawn, The Herb Handbook, Wilshire Book Company, 1973
3. Herbs in the Kitchen Corner, New England Unit of the National Herb Society of America.

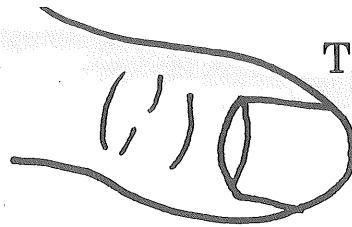

The Green Thumb Gathering

On St. Patrick's Day, from 9:00 A.M. until 2:30 P.M., twenty-five gardeners met for the "Green Thumb Gathering" at The Land. This second annual organic gardening workshop was led by Ted Zerger, Marilyn Jones, and Dana Jackson. Ted, a Salina organic gardener with many years of experience, has always willingly advised Dana at The Land Institute on gardening problems. Marilyn Jones, a Friend of The Land from Peabody, Kansas, raises organic food for her family almost year-round, extending the summer season with a greenhouse and cold frames.

This workshop was organized by categories of vegetables, such as stems and roots, cucurbits, leaves, herbs, etc. General points covered under each category were: choosing varieties, planting times, spacing and interplanting, soil and nutrient needs, watering methods, weed & insect problems, cultivation and mulching, harvesting and preserving.

In discussing stems and roots, Ted gave special attention to sweet potatoes and Jerusalem artichokes. He cut pieces of sweet potatoes from his 1978 garden, which had kept all winter, and told gardeners to place them in sand until plants started growing. Then the green stems could be broken off and placed in water to root, and later transplanted to the garden. He also encouraged everyone to cultivate Jerusalem artichokes and provided tubers for those who wanted them. After eating the clean, crisp artichokes dipped into the garlic-chives flavored goat cheese which Marilyn Jones had brought, many participants were eager to plant them.

Marilyn's presentation on herbs was a highlight of the day, and she generously shared small pots of herbs with participants. She discussed the grasshopper control strategy at the Jones Sheep Farm--guinea fowl, and described how to brood guineas most successfully under banty hens.

Participants were challenged to list the ten garden vegetables highest in vitamins and minerals on the backs of their printed agendas. The day went by so quickly and the answers were never given. So for those who attended and still wonder what the most nutritious vegetables are, here is the list as printed on page 84 of the February issue of Organic Gardening and Farming.

- | | |
|---------------------|-----------------|
| 1. broccoli | 6. asparagus |
| 2. spinach | 7. artichokes |
| 3. brussels sprouts | 8. cauliflower |
| 4. lima beans | 9. sweet potato |
| 5. peas | 10. carrots |

Alternatives in Energy

The Status of Wind Energy at The Land

Our interest in renewable energy has led us to much work with wind energy at The Land. Though safe, clean and abundant in Kansas, wind energy is not without its complications as many Land students have discovered. Currently we have four wind generators, one uncompleted windmill for grinding grain, and a wind-powered water pump, all in various stages of progress.

The 32-volt Jacobs wind-electric system on one of the towers north of the Doings Building provides 2500 watts of power. Wes bought it in 1977 from Dave Sodaman of Hays, Kansas, for \$500. Another \$800 was spent for repairs, such as replacing the hub, a piece that fits over the shaft, holds the blades and governs the machine to prevent excessive speeds during high winds. This machine has recently caused us some problems. A fuse blew in the control box. During the course of the investigation into the problem, accidental contact between the generator and the batteries was made which caused the machine to "motor." The wire, which was attached to the shaft and the tail to hold the propeller out of the wind (the spring which is supposed to do that job was being repaired), became tightly wound around the shaft and "sprung" the support for the tail. The tail had to be taken down with a block and tackle, straightened, and returned to the top of the fifty feet high tower. Karl Zimmerer, Ron Mueller and Marty Bender took turns on the top, two at a time, while Jim Peterson and I lowered the tail with a pulley and a guide rope.

On the other high tower now rests a 110-volt, 1500 watt Wincharger bought for \$800 from John Craft, an associate at The Land in the fall of 1977. John invented and built the governor for this generator and converted this four blade machine to a three-bladed one. This is a gear-driven machine, which means that propeller speed is low, but the armature speed is several times faster. Therefore, we can get by with a smaller machine, though gears do have to be maintained. It will be easier to convert the 110 D.C. to 110 A.C. than it will to convert the Jacobs 32-volt D.C. into 110 A.C.

Both these machines could provide from 300 to 450 kilowatt hours per month if they are in good running condition. The Land (house, office, workshop) currently consumes around 1000 kilowatt hours per month.

With Ron Mueller as foreman, Brian Williams, Wendell Wiebe, Curtis Carroll, Jeanne Green, Jim Peterson, Jay Burns, Marty Bender and Wes all helped build the wooden battery shed. The shed has twelve inches of fiberglass insulation on the

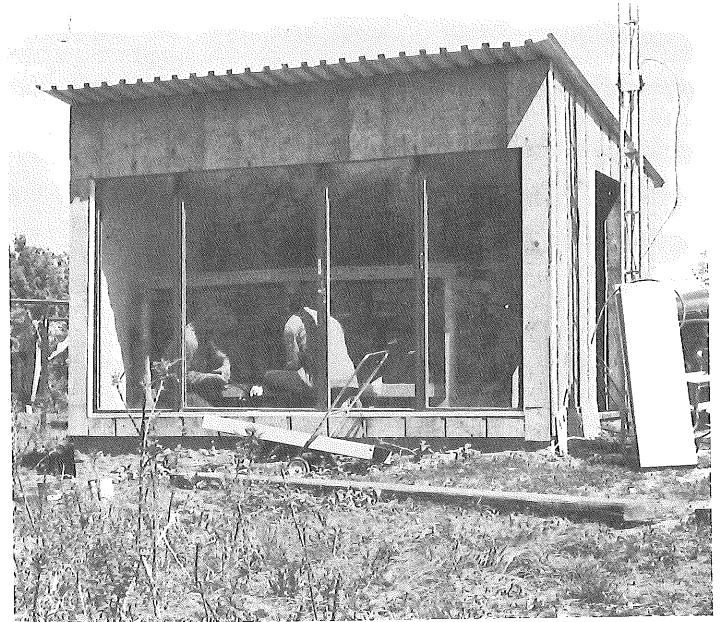

roof, six inches of fiberglass insulation in the walls, and large windows on the south side to prevent the batteries from freezing in the winter.

The large batteries, which we bought used from phone companies, cost \$18 each, and the smaller ones cost \$2.50 each. One difference between the sizes is the amount of amp/hours they can hold. The large batteries can store 1680 amp/hours, while the smaller batteries hold one-fourth that energy. Since the 110-volt generator only produces 1500 watts, it does not need a lot of storage. Hence, we plan to use the larger batteries for the Jacobs 2500 watt generator when we buy small ones.

The other difference between the two sizes of batteries is weight. Made from nickel-cadmium, a large battery requires four people to lift it. While helping move a battery, Jim Peterson got acid near his eyes and took off for the nearest water outlet. Many clothes have become "holy" through the experience of "dropping acid," as we commonly refer to it at The Land.

One must pay much attention to the care of batteries. To insure good contact, almost everyone has shared in the scrubbing and polishing of the terminals and of the strips of metal connecting the batteries together. Because of this time-consuming maintenance, as well as the expense, weight, hazards and general unavailability of batteries should everyone want them, an alternative to this type of electricity storage should be considered by those installing wind generators.

Many people may wish to store their wind-generated electricity on the local power grid. Whenever a wind generator creates more electricity than the family uses, the meter is set back accordingly, and the utility must pay the family for this surplus. (Utilities are now discussing how much money should be paid for the surplus.) To convert the direct current produced by wind generators to alternating current for the power lines, the family must invest about \$1100 into a synchronous inverter, which also reduces the efficiency somewhat. Thus, storage can be solved, but not without either invested time or capital.

Outside the battery shed stands a small, twelve-volt, 100 watt wind generator. Jeanne Green carved its two-bladed propeller out of fir wood, making sure it was symmetrical, and painted it white. She then balanced the propeller by hanging it on a string, so she could drill holes in the middle. Jeanne also replaced the springs on the two-bladed governor, since the old ones were too rusted, and attached the propeller and governor to the generator. With Karl Zimmerer's help, she discovered that one of the two copper brushes which transfer the electrical energy to the wires, was missing. After putting in a new copper brush, the generator worked.

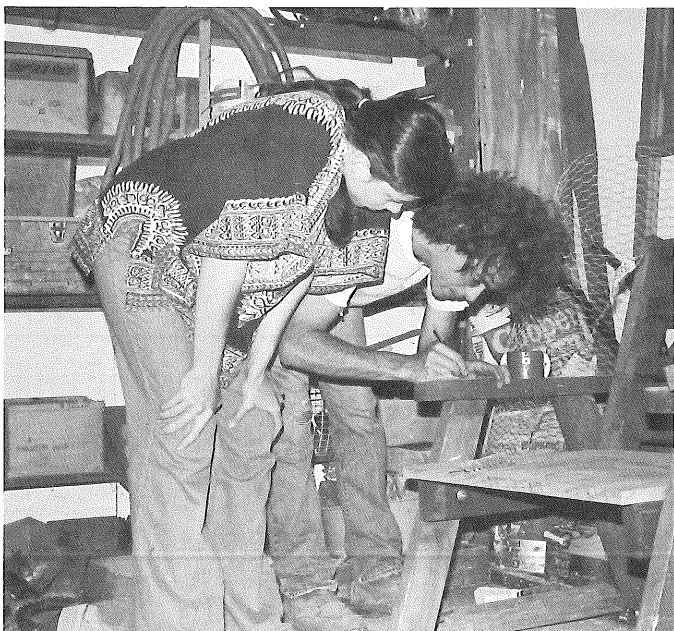

Jeanne Green and Karl Zimmerer

Ron Mueller has been working on a Wincharger generator in the Experimental Village on and off all semester. This is The Land symbol on the logo. Carl Dowd sold this generator to The Land after the first generator was destroyed in the fire in October, 1976. Like the Jacobs, this machine is a direct drive and has 32-volts, but it produces 500 watts. Ron took a couple of weeks to carefully carve and balance the two-bladed propeller.

After motoring the generator with batteries, he found it did not perform. Acting upon Karl's advice, Ron then moved the copper brushes to set up a polarity of field, but it still did not work. Frustrated, he took the generator to an electrical motors shop, where they told him the wires had been burned out from the generator's rotating too fast.

Leo Bircher from Kanapolis has loaned The Land a similar generator, to which Ron has attached the old Wincharger's tail, propeller and governor. Since the new generator worked when he motored it through the batteries, Ron has put it on the tower and hooked the wires to the batteries in the Indian House. He has one two-volt and five six-volt batteries for the total of 32 volts. We will use that energy to light the Indian House as well as to power any tools with brushes.

Besides producing electricity, wind can be harnessed to do other kinds of work. Pat Dreese worked on a windmill for grinding grain, explained elsewhere in this Land Report. Curtis Carroll and I spent a week on the wind-powered water pump. Its gears and its tower, which Curtis and I secured to four surrounding steel posts, had been placed on the river bank last year. We disassembled the six sections, containing three blades each, from an old windmill and carried them up the tower one by one. Getting the spokes through the blades and fastening the blades together with bolts was often very difficult since pieces were bent. When we had put half the blades on, a strong wind managed to rotate the blades, bending some of them because of the imbalance. Curtis and I were sure to tie the blades to the tower tightly after that setback! Now that the blades are up, we need to replace the brake and install the new pump. When complete, The Land will use the water pump either for irrigation or for the livestock.

As is evident from our experiences at The Land, wind energy takes time and effort to capture and store. Working with this renewable resource, however, has given each participant an understanding of how wind energy can be made useful.

Alissa Guyer

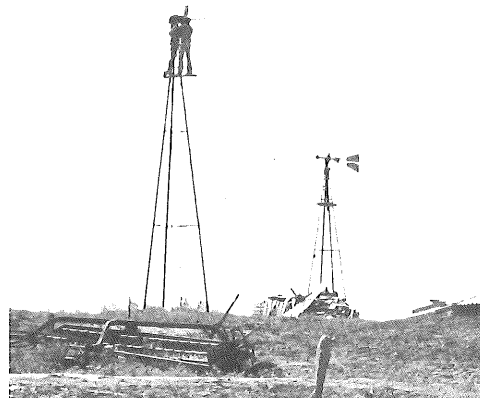

KP&L, Kansas' Largest Utility

In preparation for our Soft Energy Paths Conference last fall, Marty Bender and I obtained information about the electrical utility which services our area, the Kansas Power and Light Company. We learned some facts which should be of interest to any customer of KP&L, the largest utility in Kansas.

KP&L has generating plants in Hutchinson, Lawrence, Abilene, Tecumseh and St. Marys (Jeffrey Energy Center). The Hutchinson plant is the oldest and burns natural gas only. The plants at Lawrence, Abilene and Tecumseh can burn coal or natural gas. Jeffrey is the newest and burns coal only.

KP&L, which owns 64% interest in the Jeffrey Energy Center, is determined to have the four units of the plant completed on schedule in order to meet customers' demands for electrical power. Prior to 1973, the electrical demand had been growing at 8% per year. Since 1973 it has been growing at 6% per year. In 1977, KP&L could not meet its customer demand and had to buy power from MOKAN, which is a seven member utility pool enabling power companies in Kansas and Missouri to buy and sell surplus power according to their needs. With unit No. 1 at Jeffrey in operation in 1978, KP&L is now able to meet customer demands. Unit No. 2 is 40% complete and is scheduled for operation in 1980. Unit No. 3 is to be operating in 1982, and No. 4 by 1984. With a generating capacity of 680 megawatts for each unit, Jeffrey Energy Center will eventually generate a total of 2,720 megawatts at a projected cost of \$1.2 billion.

To provide coal for the Jeffrey Energy Center, KP&L negotiated a 40 year contract for AMX coal from Gillette, Wyoming in 1973. In response to the coming deregulation of natural gas, KP&L had the foresight to make the purchase before the Arab oil embargo. Thus the price it is paying for this coal is half what the coal companies could get for it on the open market. During the summer of 1978, it became cheaper for KP&L to burn coal than natural gas, so the total generation of KP&L is fueled about 55% by coal and 45% by natural gas.

KP&L's electricity formerly was generated almost entirely from natural gas taken from wells in southwest Kansas. In the future it will be coming mostly from coal mined in Wyoming. This means that each new KWH of electricity we consume will have worse economic and environmental effects than the last.

The economic effect which we will all notice is, of course, that our bill will be higher. Natural gas in the past has been quite cheap. Coal now and in the future will not be so cheap. A more subtle economic effect is that

the money is going farther away and there is less chance it will return to the local economy. Very little money paid to AMX Coal in Wyoming will ever return to North Central Kansas. Since we are increasing our imports to this state, we will have to increase our exports just to stay even economically. I doubt whether the price of wheat and other Kansas exports will be increasing as fast as the price of coal. If this is the case, our lot in the future will be getting worse instead of better.

There is an adverse environmental effect to burning coal. We have all read or heard about acid rain in eastern cities. If the Jeffrey plant expands to 2400 Megawatts, and if the proposed Sunflower plant is built in Western Kansas, acid rain may occur right here in Kansas.

Besides increasing the local air pollution, we would have to bear on our consciences that part of the strip mining in Wyoming is caused by us, residents of Kansas.

It is easy to blame KP&L for these environmental degradations, but I think that giving all the blame to KP&L is irresponsible and dishonest. KP&L could and should be taking more initiatives in the areas of alternative energy. They promoted higher energy consumption for years, and I think their predictions of increasing demand into the future are overstated. The fact remains, however, that demand did increase at 6% per year for several years, and for that we the consumers must take some responsibility. There is no such thing as a free lunch, so when we run our air conditioners, hot-combs, clothes dryers, etc., there are going to be economic and environmental consequences, no matter what KP&L does. For the sake of the local economy, local air, and Wyoming land, we should all conserve.

Pat Dreese

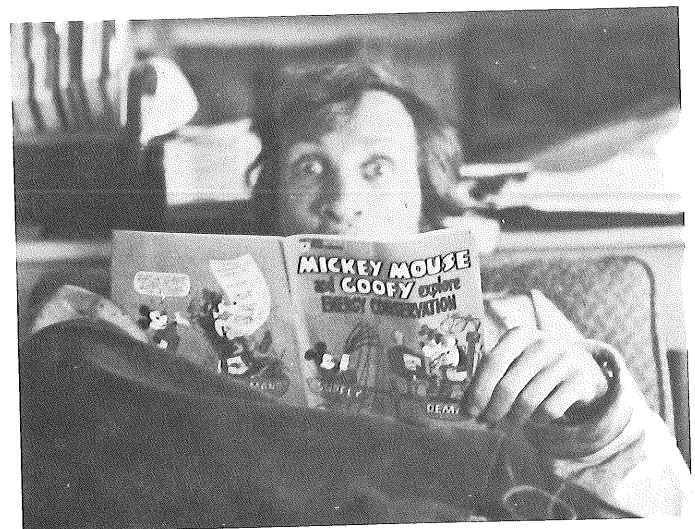

Pat Dreese is surprised to learn that Mickey Mouse equates nuclear power with conservation as an energy resource.

Windmilling Wheat

Most of the wheat we consume in the United States is first milled into white flour. From 72 to 75 pounds of white flour are made from each 100 pounds of wheat, and the remaining 25-28 pounds, mostly bran and germ, are sold as feed. Nearly all of the milling is done in centralized, large, capital-intensive, electrically-powered flour mills. These mills consume about $2\frac{1}{2}$ KWH of electrical energy per each 100 pounds of white flour produced. Large distribution systems employing trucks and railcars are used to bring the wheat in and take the flour out. I believe that the ideal way to utilize wheat would be to produce whole wheat flour milled in small, decentralized mills owned by individuals, small businesses, or cooperatives.



The small mills would overcome certain problems inherent in the current milling system. One problem with whole wheat flour is that it can become rancid during the summer. Decentralizing the milling process would lower the time lag between milling and consumption and lower the likelihood of rancidity. With smaller, less-centralized mills, the flour distribution system would be reduced and in places where wheat is grown, the wheat distribution system would be reduced. Another advantage of a small, whole wheat mill is that it could be adapted to be powered by the wind.

There might be economic problems with the small mills, however. If wages paid in the large and small mills were equal, flour milled in the small mills would cost more. The labor-productivity (pounds flour output/man-hour output) of a conventional American flour mill is tremendous. The drastic reduction in mill size would probably result in a drastic decrease in labor productivity; therefore, a higher cost per pound of flour milled. A very small mill, however, could be owned and operated by an individual for the purpose of milling flour for himself and his family, not for a cash income. The money saved from the cost of buying the flour would probably be small, but there would be other rewards.

Would an individual milling his own flour encounter problems with the storage or cleaning of wheat? How much money and labor might it cost to build a small mill? How much time would it take to operate the mill once built? How much maintenance? What would be the baking properties of the flour?

None of these questions has a single answer. Each depends upon the person and the milling system chosen. In thinking about these questions though, I decided that building and operating a small, whole wheat mill would be instructive in determining the feasibility of small whole wheat

mills in general. For my project I chose to build a wind-powered flour mill.

There is a hand-powered grain grinder at The Land which seems to be fairly efficient. The RPM at which it is operated can vary over a wide range with no detrimental effects to the flour or the machine. An increase or decrease in the speed results in an increase or decrease respectively in the amount of flour produced, but not in a change of quality. I chose to use this grinder and build a wind system to power it.

This system is diagrammed in figure 1. An eight feet diameter multi-bladed fan catches the wind. Two old auto differentials are used for gearing: one is mounted at the top of the tower with the drive shaft pointed down; the other is mounted at the bottom of the tower with the drive shaft pointed up and connected to the first drive shaft. The fan is mounted on one of the wheels of the top differential. The other wheel is locked in place so that when the fan turns, the power is transferred to the drive shaft and then on down to the two wheels of the bottom differential. Locking one of these wheels causes all the power to be transferred to the wheel left free. A "V" belt could be mounted on this wheel and another on the input shaft of the grain grinder, completing the drive.

The first big problem was how to mount the top differential so it could turn into the wind. I bought an industrial bearing with a four inch bore at a local salvage yard. The drive shaft fit down the middle of this with room on all sides. I mounted the bearing housing on the tower and the differential on the turning part of the bearing.

The next problem was mounting the fan on the wheel. I first put together an old set of fan blades and bolted the fan to the brake drum which had some pieces of angle iron welded to it. The brake drum was made to be bolted to the wheel.

The tail had to be mounted on the differential so that the fan could be turned into or out of the wind. I mounted the tail on a make-shift hinge in such a way that it could be turned parallel to or perpendicular to the differential axle. I attached a spring to the tail and the differential so that when the tail was in either the parallel or perpendicular position, the spring would be holding it there. A rope tied on the end of the tail would enable a man on the ground to pull the tail from one position to the other.

All of the parts were assembled on the top of the tower while it was on the ground. We tried to pull the tower to its upright position using a chain and a truck, but this proved to be too big a task. The next morning, heavy industry rolled onto the land in the form of a crane from Salina Crane Rental, and the tower was up in a very short time.

My elation at having the tower raised was

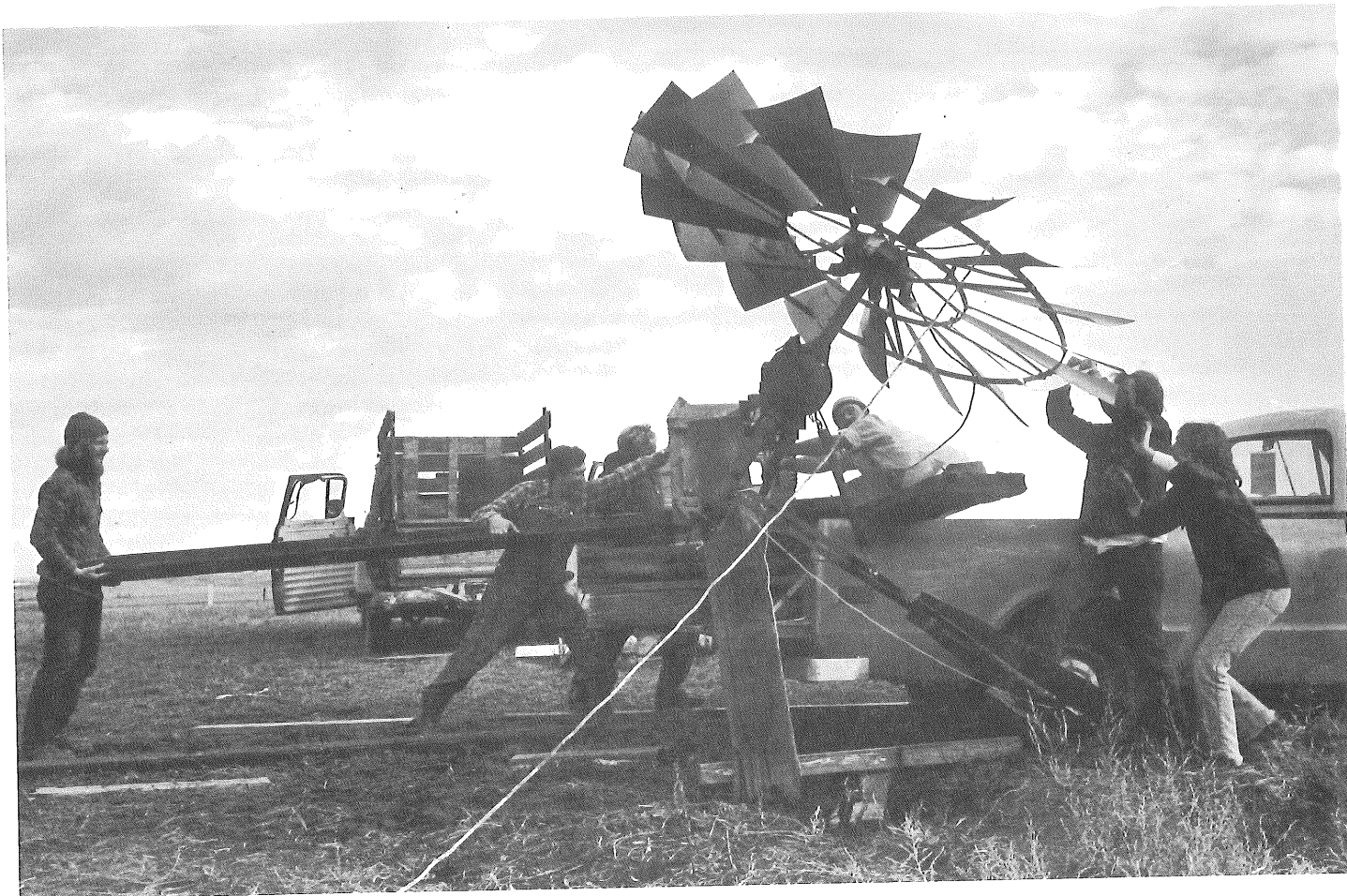

spoiled when the gallon and a half of oil which I had poured in the differential came dripping out as soon as we started tipping the tower up. The oil seal around the drive shaft obviously was not doing its job. To replace the seal would have meant taking the whole differential down. I decided to see if it would run dry.

There were other problems. The fan blades were badly bent, and they vibrated so hard I was afraid they would tear apart, so I tied the fan to the tower where it couldn't turn. I had slotted the holes for the bolts holding the industrial bearing to the tower in order to be able to do some adjusting in case the top assembly did not appear to be level after the tower was up. Slotting the holes proved to be a mistake. Though the top assembly appeared to be level when the tower was first raised, the next day we noticed it was leaning considerably. The bolts had slipped in the slots. I used two hydraulic jacks to move the assembly back to horizontal position, and with considerable difficulty was able to bolt it there so that it couldn't move anymore. I had bolted two strips of metal to the differential and to the "rail" wheel to keep it from turning. But somehow the wheel turned about thirty degrees, causing another problem. This turned the "stop" which I had planned for the tail to rest on while in the parallel or axle position. Correcting this

required leaning way out from the tower, wearing a good strong safety belt.

By this time the end of the semester was near, and it was evident that I would not have time to complete the wind drive for the grain grinder. Being unable to finish the project, I cannot say much about the feasibility of a wind-powered whole wheat mill. Some might conclude that the fact that I worked many hours and did not complete the project is evidence that building things for oneself is a bad idea. I would answer that working on this project and being forced often to use my creativity in deciding how to continue, making mistakes and paying for them has been a valuable experience. It was time well-spent.

Pat Dreese

Women's Sun Day Energy Conference Held

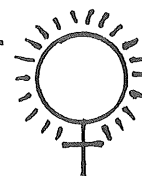

On the anniversary of the first Sun Day, May 3, Salina women met to have lunch together and discuss the role of women in promoting energy conservation and renewable resources. They discussed the importance of demystifying energy for women and considered what information women want and need to have in relation to home consumption and community consumption of energy. How can women as citizens of local communities influence energy-related decisions? was

one important question addressed.

Ideas and suggestions from this meeting were shared by Dana Jackson at a brainstorming meeting in Harper's Ferry, West Virginia on May 9-11. Twenty-four women in the fields of communication, science, technology, energy, agriculture and community organizing met to design pilot programs for a national energy education project directed to women. Consumer Action Now's Council on Environmental Alternatives, Inc. has received a \$40,000 grant to inform American women about conservation and renewable energy sources and help get them more involved in energy-related decision-making.

Civil Disobedience vs. Uncivil Obedience

The nuclear issue in the United States has permeated the public consciousness in the past few weeks as it never did before. The Three Mile Island Nuclear Power Plant accident sent a shock wave of concern through the country about the safety and economics of nuclear power. On May 6, 60,000 to 75,000 people gathered at the White House to express opposition to our nation's plutonium-oriented energy policy.

There have been various large demonstrations around the United States in the past few years, many of them aimed at halting the construction of particular nuclear power plants. For several years opponents of the Wolf Creek Nuclear Plant have gathered in Burlington, Kansas or the nearby John Redmond Reservoir early in June to voice their fears about the dangers of nuclear power plants, and their doubts about the economic validity or the necessity for building the plant. Temporary delays in the construction of the Seabrook Nuclear Plant in New Hampshire were won by demonstrators, but Kansans have not been as successful. Work continues at Wolf Creek, even with the quality and durability of the concrete base in question, and distrust of the NRC growing.

Local opposition to the plant has not effected any change. Burlington area farmers who did not wish to sell to the utilities were forced to sell their land through the condemnatory process of eminent domain. Opposing farmers were awarded very low sums of money for their land, while those who sold willingly received much more. Some reluctant farmers were left with court costs in excess of \$8,000. Harassment of those farmers has included threats to remove utility poles, orders to move an entire dairy farm off the land within 48 hours, bulldozing buildings on a farmer's property before proving the need for use of that land, and even shots fired by an off-duty deputy sheriff upon a farmer and his son who were making hay on their own land. (This case is now under litigation.)

The local opponents to Wolf Creek are steadfast in their commitment, but they have caused no delay in its construction.

Legal intervention since 1973 has not affected any changes in policy or construction. MACEA (Mid-America Coalition for Energy Alternatives) showed clearly that the need for Wolf Creek was not demonstrated in the environmental impact statement which prefaced the construction license. There is a natural gas plant near Wichita, the Gordon Evans II, which, if converted to coal, could satisfy Kansas' energy needs. It is likely that some of the electricity generated at Wolf Creek will be exported to Nebraska. These considerations were not explored when Wolf Creek promoters demonstrated the "need" for the plant and acquired their construction license. Litigation to re-open the hearings to include this information has been unsuccessful. Legal intervention has, thus far, been ineffective.

Wolf Creek is 30% completed, has involved \$500 million and is expected to cost perhaps \$2 billion or more by the time it is constructed (1983) and decommissioned at the end of its thirty or forty year life span.

The major component of the reactor, the reactor vessel which will hold the uranium fuel rods and contain the fission reaction, was delivered to the site on January 12, 1979, after a twenty minute delay caused by the Kansas National Guard. I was among thirty-six citizens who were arrested that day for bodily blocking shipment of the vessel. Members of the Kansas National Guard utilized non-violent civil disobedience as a last resort action. Demonstrations, local opposition and legal intervention had failed to halt or delay construction, and civil disobedience was considered the only option left which might make a difference.

Although civil disobedience has long been recognized in this country as a just means of initiating change when all other means are blocked by social norms, government, or corporations, reactions to the National Guard have been mixed. Somehow, memories have faded, and the untempered respect for property and for the law is demanded above all. How quickly is forgotten the courage and validity of a black woman's refusal to go to the back of the bus in Selma, Alabama, a defiance of the law. Our history is dotted with other examples. The women's suffrage movement utilized such tactics as tax evasion, vigils and hunger strikes, and public demonstrations. The labor unions in the thirties effected change with sit-down strikes and boycotts, forms of civil disobedience.

The results of the Nuremberg trials announced to the world that human rights preempt national and international laws, and that individuals are responsible for their actions or inactions. "Crimes against international laws are committed by men, not by abstract entities.

SOFT AGRICULTURAL PATH:
TOWARD A DURABLE LAND



HARD AGRICULTURAL PATH:
TOWARD A DESPOILED LAND

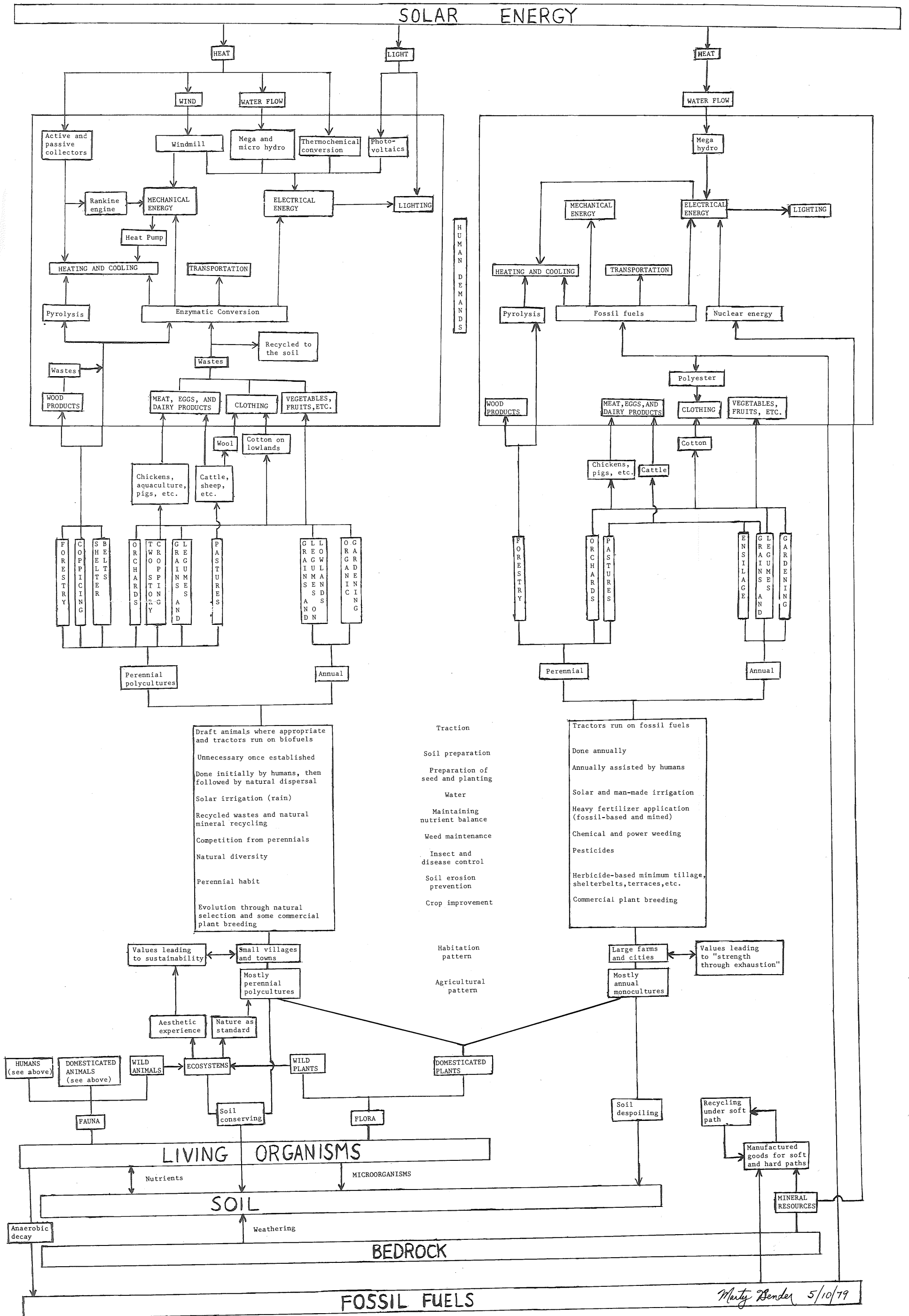

(contd. from pg. 15)

..Individuals have international duties that transcend national obligations of obedience imposed by individual states. " ²

Yet, when one looks at the current status of the nuclear controversy, one finds that those who are opposed to widespread radiation pollution and resultant increases in cancer, leukemia, and genetic mutation, those who advocate local control of simple, non-polluting energy systems, those who fear for their children's lives and

who refuse to participate in the moral outrage of imposing life-threatening radioactive wastes on generations to come, those who feel compelled to attempt obstruction of a suicidal energy path are awarded jail sentences and fines. Members of the Kansas Natural Guard were convicted and fined \$100 each. On the other hand, those who commit crimes of "uncivil obedience" in this country such as willful deception of the public concerning hazards of low-level radiation, consistent suppression of reports and studies implicating these hazards, continued use of public funds for propaganda campaigns promoting "clean, safe, cheap" nuclear energy and monopolization of tax monies for production of fissile materials rather than simple, feasible technologies such as solar, wind, bioconversion and conservation are rewarded. People who commit crimes such as these hold high-paying government jobs and receive promotions and prestige.

Attitudes are changing though. Nuclear opponents in Illinois were acquitted of criminal trespass on the grounds that the Zion nuclear plant presents a constant and grave danger to the population. Their defense was based on the Illinois statute of "necessity." ³ In Claremore Oklahoma, charges against 132 anti-nuclear energy protesters accused of trespassing were dropped after nine and a half hours of compelling testimony on the hazards of radiation, and all the other problems associated with nuclear power. The judge searched for a technicality in the case, found it in the prosecution and dismissed the charges. ⁴

The Kansas Natural Guard members who were tried in March were not allowed to use the "compulsion" defense (compelled to resort to civil disobedience because of the imminent danger of nuclear power). The judge ruled that the Wolf Creek Nuclear Plant must be "hot," (radioactive) before that defense can be used. The case is on appeal however, and eleven persons still await trials.

Members of the Kansas Natural Guard were required to take non-violence training before they could be a part of the group blocking the train to prevent the reactor vessel from being delivered. They were well aware that charges would be filed against them, that they could spend time in jail and would likely pay fines. Those whose commitment led them to the Wolf

Creek Nuclear Plant in January included farmers, middle-aged homemakers, priests, engineers, senior citizens, young mothers and college students. These Kansas citizens chose civil disobedience as an alternative to uncivil obedience.

Jeanne Green

Notes and References

¹A series of four excellent articles by Max McDowell about the concrete problems at Wolf Creek appeared in the Emporia Gazette April 9, 12, 26 and 27. The public first learned of the base problem on December 13, after an internal memo by the Nuclear Regulatory Commission was "leaked" to the K. C. Star. Max McDowell refers to this and other recent NRC documents about the concrete inspection in a full account which is not very reassuring to a public concerned about the safety of nuclear power plants.

²From the Nuremberg Principles.

³This case is described in an article by Casey Bukro, environment editor of the Chicago Tribune, called "Out, Lorax--the Antinuclear Protesters Have Arrived," on February 6, 1979.

⁴These protesters were members of the Sunbelt Alliance working against the Black Fox Nuclear Plant near Inola, Oklahoma. A short note about their trial appeared in the K. C. Star in March, 1979.

Join The Groundswell Opposition
on the

**INTERNATIONAL
DAYS OF PROTEST
AGAINST
NUCLEAR POWER!**

June 9th
JOHN REDMOND RESERVOIR
BURLINGTON, KANSAS 12 NOON

Music, Speakers &
other Attractions!!

A Legal Rally
sponsored
by the



**Sunflower
Alliance**



The Rally Site

- theme -
NO NEED FOR
WOLF CREEK!
(We all live in
Pennsylvania!)

The Alternatives Network

RAIN

NEW
CRITERIA

THE MIDWEST
JOURNAL OF
APPROPRIATE
TECHNOLOGY

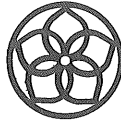

Intermediate Technology

TRANET

New Alchemy

WINDPOWER
DIGEST

ACORN

The New Alchemists

The objective of this Alternatives section, as outlined the Land Report Number 5, is to describe and promote the various groups in our region and assist or facilitate communication among them. In general we do not intend to devote space to organizations beyond the Great Plains Region; however, with this issue we present our first very important exception.

The New Alchemy Institute is located on Cape Cod in Massachusetts. It is probably the most famous of all the "New Age" research/education organizations in the network. Many widely-circulated magazines have carried articles about it (See National Wildlife, April-May, 1979), and the public television program "ZOOM!" has featured the children of the New Alchemists.

We first learned about New Alchemy in 1973, and were inspired by their efforts "To Restore the Lands, Protect the Seas, and Inform the Earth's Stewards." Through their beautiful journal we became informed about their aquaculture projects and intensive bed gardening. In April, 1979, we had the opportunity to visit the Institute and spend a week with the "Alchies" at a conference which they arranged.

The approximately twenty New Alchemists work on a twelve acre "farm" which contains various small experimental greenhouses and the Ark, a large bioshelter, entirely solar heated, which produces vegetables all year. A major element in the Ark is the research being done on fish culture in algae-green plastic pools. The fish ponds absorb so much solar energy during the day and release it at night that no backup stoves have been necessary, even in the coldest part of winter. The diffused light coming through the curved plastic roof creates a lovely atmosphere in the greenery-filled Ark. Visitors entering the Ark respond with a kind of hushed awe.

Outside the intensive-bed gardens, tree crop research, and various fish culture experiments are not there simply to produce food, or to demonstrate neat ideas. Careful records are kept and experiments are cautiously designed and evaluated. Some failures occur, as they do at The Land, and certain members of the scientific establishment are skeptical of the value of such research. However, as modern agricultural methods, researched and taught in land-grant

universities are depleting and poisoning soils, alternative approaches must be sought somewhere else. The New Alchemy Institute is funded by those individuals and foundations well aware of a future which must be different from the past and willing to invest in experiments for the future.

Another ark designed by the same architects, Ole Hammarlund and David Bergmark of Solsearch Architects, was built on Prince Edward Island, Canada with funding supplied by the Canadian government. The New Alchemists also have a center in Costa Rica directed by Bill McLarney.

To learn more about the work of John Todd, Al Doolittle, Hilda Maingay, Earl Barnhart, Susan Erwin and all the others, you can become a subscribing member (\$10) or an associate member (\$25) and receive the yearly Journal of the New Alchemists, a beautiful publication edited by Nancy Jack Todd.

write to - The New Alchemy Institute
P. O. Box 47
Woods Hole, Mass. 02543

The Village as a Solar Ecology

"The Village as a Solar Ecology: a Generic Design Conference" was convened by John H. Todd and Nancy Jack Todd on April 16 on Cape Cod. The purpose of the conference was to determine whether it is possible to design a village that is a solar ecology, using modern scientific knowledge, ancient techniques of building and siting, and relying exclusively on renewable sources of energy. It was inspired by and dedicated to Margaret Mead, who was the first to see that the New Alchemy Arks or bioshelters belonged on a scale other than the household or the small self-contained homestead. For her the blending of architecture, solar, wind, biofuel and electronic technologies with housing, food production and waste utilization within an ecological context was the basis of creating a new design science for the post-petroleum era. Dr. Mead was excited by the Arks, but in her opinion the scale was not right. "Arks and villages belong together if people are to relate to them," she said.

Although much of the design approach at the conference was based on New Alchemy experience

with the Arks as bioshelters, an extremely diverse and creative group of participants extended this enormously. Architects Malcom Wells (famous for underground houses), Sim Van der Ryn (former California state architect), Paul Sun (designer of Quincy Market in Boston), David Bergmark and Ole Hammarlund of Solsearch Architects who designed the Arks, energy expert Amory Lovins, a wastewater treatment expert named Steve Serfling who is a pioneer in Solar Aquasystems, and several others (not easily pigeon-holed) competent in numerous technologies, spoke of the physical elements which should be a part of a village of the sun. William Irwin Thompson of Lindisfarne, Mary Catherine Bateson, anthropologist-daughter of Margaret Mead, and Keith Critchlow, author and lecturer of the Royal College of Art in London, the Very Reverend James Morton, Dean of the Cathedral of St. John the Divine in New York City, and public interest lobbyist and organizer Byron Kennard guided the group through the important spiritual and social considerations in designing the solar village. Spirited debates over space and population, growth within the village, economics and geographic limits, the importance of symbols, etc., was inevitable, stimulating, exasperating and eventually productive.

William Irwin Thompson, elaborating on some of the ideas eloquently expressed in Chapter 2, "The Metaindustrial Village," from his book, Darkness and Scattered Light, presented an opening lecture which set the tone for the conference. "We must understand the village as something in and of itself, not on the way to becoming a city. We need to balance communal process with architectural excellence...We must not idolize cultural peaks and ignore indigenous needs and style...but the counter culture has been swung too far the other way."

Paul Sun gave a fascinating presentation about the traditional Chinese concept of Feng Shui which guides the location and orientation of dwellings. Modern mainland Chinese reject Feng Shui as superstition, but Paul illustrated how scientific truth underlies the metaphorical myths, and stated that the wisdom should be put into a modern vocabulary so everyone could understand.

In her talk, Mary Catherine Bateson brought up some very important questions to consider in the generic design of a village. What is the right size for the village? How far should it be from other villages or towns? What kinds of diversities or cultural life will exist in the villages? Would the village be self-built as well as self-fed? Would the community produce its own spouses?

"Peasants do not love nature. City people do!" Mary Catherine went on to explain that primitives and peasants know about those aspects

of nature that concern them because they have to live there next year and they learn how to live as harmlessly on earth as possible. For example, they know better than to dirty their own wells. "Can they develop a consciousness of love for nature as they are using nature!" she asked.

During the week-long conference, the elements which would be the basis of energy and food production in a village of solar ecology were discussed by several of the New Alchemists. Joe Seale talked about integrated electrical systems. Coleen Armstrong and Kathi Ryan talked about the value of Arks in relation to food growing and as educational centers. Earl Barnhart described the advantages of tree crops for human food and animal forage, for slowing soil erosion and filtering dust, and for enriching the culture of the village. David Bergmark and Ole Hammarlund showed ideas for climatic envelopes. While the concept of an Ark as a climatic envelope controlling the environment was acceptable to the conference participants, almost everyone reacted negatively to a proposal by Jay Baldwin that a village of the sun be entirely covered by a Bucky Fuller-inspired dome 1200 feet high. After considerable discussion, most realized that it was the size of the dome, the scale of the "semi-permeable membrane" which was disturbing. Dick Dowd of the E.P.A. in Washington suggested that perhaps communities might be organized with houses on the edge of the dome roof with an elementary school and community space in the center. At that scale it might be acceptable.

Jan Adkins, writer and illustrator of children's books, engaged everyone in assisting him with the plot of a book he is writing. The inhabitants of an island lose their electrical generator in a storm and decide not to replace it but to become a more self-sustaining solar village. What happens? Modeling the imaginary village was an exercise which prepared the conference participants to consider three potential village developments: a 100 acre site for a small village on the coast of Maine, a 1700 acre site (800 acres under water) on the former Hamilton AFB in Marin County, California, and the conversion-adaptation of the thirteen acre Close of the Cathedral of St. John the Divine in New York City into a "New Age" demonstration. A Cathedral Ark could engage the people in nearby neighborhoods, as well as the 2500 daily visitors, as workers in the gardens and students of solar energy and aquaculture.

The conference participants formed three groups to consider the three potential solar villages. As design principles previously discussed were applied to the specific sights, amazing ideas and images resulted. Sym Van der Ryn had said earlier, "We need images people can relate to. Then the images will create the reality." There was an air of excitement as

each group explained the sketches for the different designs on the last morning of the conference.

When John Todd opened the second day of the conference with a talk entitled "Ecology and Design," he suggested a value system for the development of communities seldom recognized in current design. "The biosphere needs must come first before human needs. If they don't, then any solution is short term." The groups kept this in mind as they discussed potential industry and the economic base for the villages.

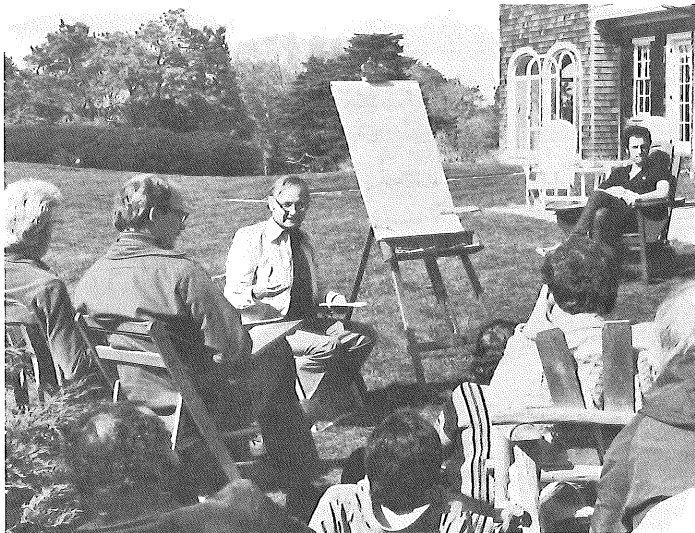

Maurice Strong discusses the economic resources needed in the establishment of solar villages.

This article has in no way covered the multitude of issues and considerations raised during the conference, nor has it mentioned all the participants and their unique contributions. The New Alchemists will publish a document about the conference to stimulate a widespread interest in the concept of the village as a solar ecology. Architectural drawings, sketches, images and landscapes produced by the numerous illustrator/architects will accompany the text.

In the summer of 1978, Margaret Mead urged the Todds to get on with the task of developing images of the village as a solar ecology, saying that there was little time to waste if the human community was to have genuine alternatives to the dubious atom. Meeting in the wake of the Three-Mile Nuclear Power Plant Accident in an area where 35% of the electricity is provided by nuclear power plants, participants felt a special urgency and sense of important mission to make their images, their vision, into reality.

Dana Jackson

Dana Jackson at work in the office. ↗

Max's Pot

The center for Maximum Potential Building Systems (referred to locally as Max's Pot) is a non-profit research and educational facility located in central Texas. Its function is a regionally-based appropriate technology lab. The Center is concerned with environmental and resource issues, but not apart from the socio-economics of a region in its own right. Their personnel have included planners, engineers, sociologists, economists, masons, writers, architects, carpenters and lawyers. They have been involved in ecological land planning and appropriate technology design for Hill Country Youth Ranch in Ingram, Texas and mesquite wood management and installation of over 900 wood burning stoves with solar collector program in Crystal City, Texas. They have publications for sale relating to their building projects. Write to Center for Maximum Potential Building Systems, 8604 Webberville Road, Austin, Texas 78724.

Audubon Wildflower Book Published

Favorite Prairie Wild Flowers and Grasses, written by Mary Louise Johnson, designed and illustrated by Iralee Barnard, and edited by Dana Jackson, is the first publication of the Smoky Hills Audubon Society. It includes non-technical descriptions of 45 of the most common wild flowers and six grasses in Saline County, with charming tidbits of Indian lore and notes about the names of plants. The book is available for \$2.00 from The Smoky Hills Audubon Society, Box 173, Salina, Kansas 67401.

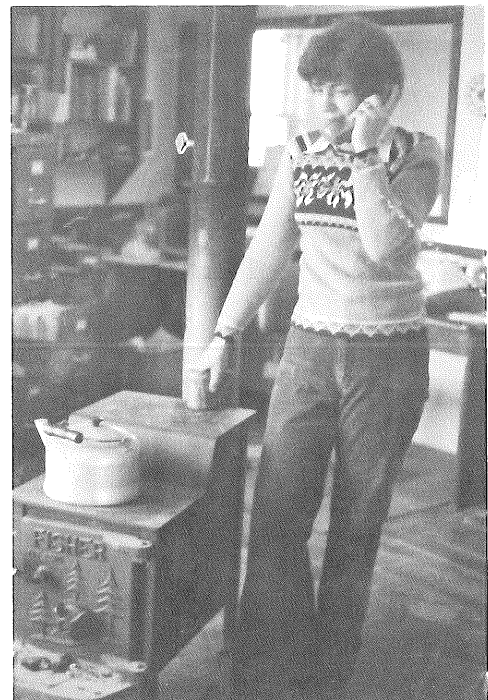

Half Asleep Near the Three Rivers

By Harley Elliott

A sparrowhawk
eating in the
tree above me

delicate grasshopper shells spiral down.

The red cottonwood flowers fall
like daggers on the river.

Saline

Solomon

Smoky Hill

Three long breaths
in the quiet-hearted afternoon.



Spinach noodles, whole wheat alphabet macaroni, raw cashews, wheat and rye flakes, sesame tahini, lentils, and alfalfa sprouts are food products new on the grocery lists of some Salina people. The Prairieland Food Cooperative, 707 Bishop Street, offers these and many other whole foods to a growing membership interested in a wholesome diet. More meatless meals are possible when one learns how to use soy grits, brown rice, barley, and whole wheat products in the right combination with affordable cheeses and nuts and seeds. Several new shelves of herbs and teas now provide more options in preparing creative dishes and drinks.

Working members of the co-op belong to 5 collectives: PROCUREMENT (food ordering), FINANCE, MARKETING (pricing, membership), BUILDING/MAINTENANCE, and OPERATIONS (clerking, packaging). Non-working members pay 1.50 times working member prices. The co-op is democratically inefficient, communications are sometimes poor, and certain jobs are really boring, like washing bottles. And there is no "quick check out" on Saturday! People stand around talking, exchanging recipes, and complaining that needed items "did not come in." But the co-op will thrive, because it is an example of ECONOMICS as if people matter.



Prairieland
food cooperative, inc.

Alternatives in Shelter

Indian House Has New Roof

Construction on the Indian House, an alternative shelter located in the Experimental Village, began in September, 1976. The first students to get material together and begin building the frame were Sue Leikam and Nancy Vogelsberg. Their idea was to erect a shelter that in theory could house at least one family, using the resources from this area only. Sue and Nancy modeled the house after the remains of an Indian lodge found just two miles south of The Land in a dig supervised by the late Dr. George Taylor of Kansas Wesleyan. Nancy and Sue's description of their efforts appeared in the very first Land Report, December, 1976.

When Sue and Nancy left at the end of the semester, the hedge pole frame of the shelter was standing. David Kearns, who attended during the fall semester, 1977, took on the project. He strengthened the frame and began experimenting with tamped earth for the walls. Jeff Brown then continued the work during the spring semester, 1978, and a procedure and process for constructing tamped earth walls evolved. Land Reports 4 and 5 contain reports by Dave and Jeff respectively on their efforts.

During Brian Williams' first week at The Land in September, 1978, he decided to try to complete construction of the Indian House. About one-third of the wall was left to be built, the entrance to the shelter had to be repaired, and the rafters needed to be laid down to accommodate a sod roof. Brian and Wes decided to use a sod roof because of its high insulation value, and they planned to cut the sod out of the pasture.

Brian spent the first few days making repairs on the square frame in the center of the house. Then he replaced the high beams, which were osage orange poles, with used 2x6's that Wes bought from a salvage yard, a change necessary to achieve a level surface on which to place the sod. Brian and Wes were aware that the boards violated the principle of using only local material. Brian estimated that he would need about 48 rafters spaced two feet apart to cover the 96 feet circumference of the shelter.

After he had put about half of the rafters into place, Wes and he decided to complete the earth wall before continuing any further on the roof. This was about the time the temperature began dropping below freezing, so Wes hired a bulldozer and operator to break the frozen ground and move the dirt up towards the walls. Then Brian began building up the dirt wall.

The end of the first semester came, and there was still no roof on the Indian House. When Jay Burns came to work at The Land in February

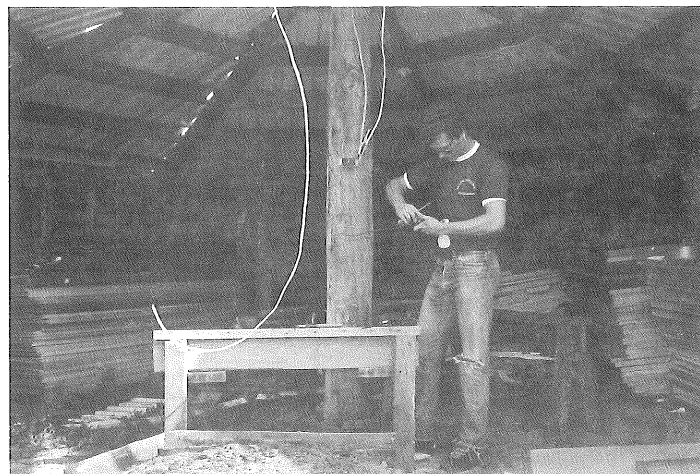

Ron Mueller works on wiring from the small Wincharger which provides electricity for lights in the Indian House.

as a CETA employee, Wes asked him to finish the roof. He and Jay redesigned the plans in order to use the strong-barn metal roofing which was available. First Jay removed the four hedge poles in the middle and put in one large power line pole. Then he placed eight 2x6's so that they met in the middle, each resting on the center pole, and formed eight equal wedges. The wide side of each wedge was braced with additional 2x6's.

Next Jay sawed the metal roofing to fit the wedges. The pieces overlap at the seams within the wedge, but not over the rafters, so he capped those seams. The metal roofing extends over the outside circumference, protecting the walls when it rains.

The original intent of this Indian House Project was to construct a shelter made only from local materials. The rafters and the metal roof are not local resources. But Wes decided that after 2½ years and five students working on the Indian House, it was time to conclude the project and use the shelter. The building now is used for storing stacks of patio doors and other materials.

When asked why he decided not to continue with local materials only, Wes replied, "We failed. We aren't smart enough to live in a third world country."

Wes's answer does not mean that The Land Institute has abandoned its principle that regions should develop construction techniques utilizing local resources. The adobe walls of the growhole and tamped earth walls of the Indian House were experiments in using the clay soil found at The Land. Perhaps future students or research associates will have ideas for building roofs and roof supports from local materials.

Alternatives in Waste Disposal

Barrel Composting Toilet Installed

Our system of disposing of human wastes is really ridiculous. Each flush in a toilet requires five to seven gallons of good drinking water to wash away waste to a centralized treatment plant where wastes and water are separated and the water is returned to the consumer. Approximately 42% of residential water usage is for the transportation of human waste.¹ Not only is this a poor use of water resources, but a waste of potential fertilizer.

During the 1978 fall semester at The Land, I became interested in composting toilets as better technology for the disposal of human wastes. I learned that there are several different types of composting toilets. Two commercially available for household use are 1) the large composting toilet with few moving parts, consisting of a tank with an inclined floor and a capacity of at least one cubic yard; 2) the small types with an electric heater, a fan in the tank, and possibly a mixing arm. An example of the first type is the Clivus Multrum which can be used by four to six people. The large box of fiberglass or other impervious material has a bottom sloped at an angle of twenty to thirty degrees. A continuous flow of air through the material at the bottom aides in the composting process as the wastes reach the peat moss starter.² The smaller units depend upon electricity to heat, provide circulation by a fan, and in some cases blades to stir the composting material. Warmer temperatures produce rapid decomposition and evaporation of liquid. These require a space of two to four cubic feet from the base for installation. A vent stack is required ten feet above any point and two feet from the base as a back-up system should the electric fan fail. These units can serve three to five people, though overload can be a problem.³

Other outdoor choices are pit and bucket privies, earth closets, barrel or drum privies and vault privies. The Farralones Institute in California has a vault compost privy which consists of a superstructure or housing extension over an impervious chamber which receives and composts human body wastes. The composting chamber is constructed of concrete and cement blocks to provide a sanitary barrier between wastes and the immediate environment. The vault is divided into two parts by a wall in the middle to allow composting of one side while the other side is in use.⁴

For a project during the fall semester, I chose to use the barrel composting method for its convenience in maintenance and handling during the composting period. When the barrel is full, it is tightly sealed, painted black, and set out

in the sun for the wastes to decompose. Once a month or so it should be rolled vigorously.

The first job was to prepare the building to house the composting toilet. Wes bought a building last summer for twelve dollars which had been used to test crank cases. The walls inside and out were soaked with oil and dirt, so I scraped and painted them. We leveled the dirt floor, then covered it with pallets and bricks.

Pat Dreese and I made a trip to the local pizza factory to acquire two 55 gallon drums that formerly contained pizza sauce. The idea was to have two barrels, one for composting while the other is in use, but I was able to complete only one barrel before the end of the semester. After studying plans in Rural Wastewater Disposal Alternatives, we came up with a plan for adapting the barrels to our purpose. Wes and I drilled a hole in the side of the barrel six to eight inches from the bottom for a three-fourths inch close nipple. The nipple connected on both sides to a ninety degree elbow galvanized pipe that held three-fourths inch plastic pipe. The inside pipe had holes drilled for air to circulate through the waste. The outside pipe led to a hole in the back wall behind the barrel. Small mesh screen was placed over the end on the outside pipe to keep small intruders out. (See illus.)

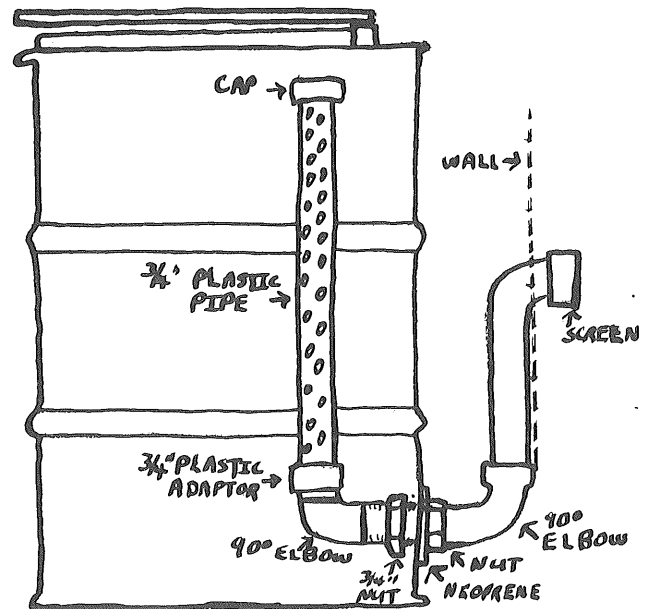

Most people respond negatively to the idea of a composting toilet, located indoors or outdoors, as the thought is related to a lingering smell once experienced in an outhouse. However, a properly operating composting toilet

should have no disagreeable odor. Excess moisture, the cause of odors, is prevented by the addition of organic material to absorb the moisture and by proper venting. (The venting system does work in our barrel.) Arrow, a friend of students at The Land, visited one day while I was working on my project and told me about the composting barrel privy he had built and how it had worked. To solve the liquid build-up problem, he simply asked users to put only solid waste into the composting toilet. Rather than do this, I decided to make sure enough organic material would be available to add. For an initial start, six to eight inches of dry wood shavings were placed in the barrel. (Shavings are better than sawdust as they are more absorbent and allow more air circulation.) I placed a bag of leaves and a barrel of sawdust with a measuring container in the building, then put a note on the wall telling visitors to add the leaves and sawdust after every use.

The seat for the barrel was made by cutting a hole in the top and attaching a plastic toilet seat. We placed a large block of wood in front of the barrel to help short people climb up and to provide a place for dangling feet to rest.

Although disease organisms are not supposed to survive the conditions of aerobic decomposition (160 degrees F. in the center of decomposing matter), some health officials recommend using the resulting humus from the composting toilet for fertilizing shrubs and flowers, not vegetables. We shall probably use the humus at The Land on the trees and shrubs.

The barrel composting toilet is appropriate for The Land. But there are many other kinds of systems which are practical for urban as well as rural settings. The state of Maine was the first state to recognize the value of composting toilets and has encouraged their use if they meet certain standards of performance.⁵ After the drought in the West in 1977-78, California and Oregon communities began to look more favorably upon composting toilets as they faced a water shortage. As the costs of large, centralized sewage treatment plants increase, more individuals and communities will realize the potential of the composting toilet. The end of the flushing era may be in sight.

Carol Maguire

References and Notes.

¹Van der Ryn, Sim, The Toilet Papers. Santa Barbara, California: Capra Press, 1978. Pg. 81.

²The Toilet Papers, pg. 39.

³Lane County Office of Appropriate Technology, "Composting Toilets." Eugene, Oregon. pg. 4.

⁴California Office of Appropriate Technology, Rural Wastewater Disposal Alternatives: Final Report - Phase I. State of California, Office of Planning and Research, Sacramento, California, 1977, pg. 30.

⁵Moreau, Eugene, "Maine's Perspective on Composting Toilets and Alternate Graywater Systems." Department of Human Services, State of Maine, Augusta, Maine, 1977.

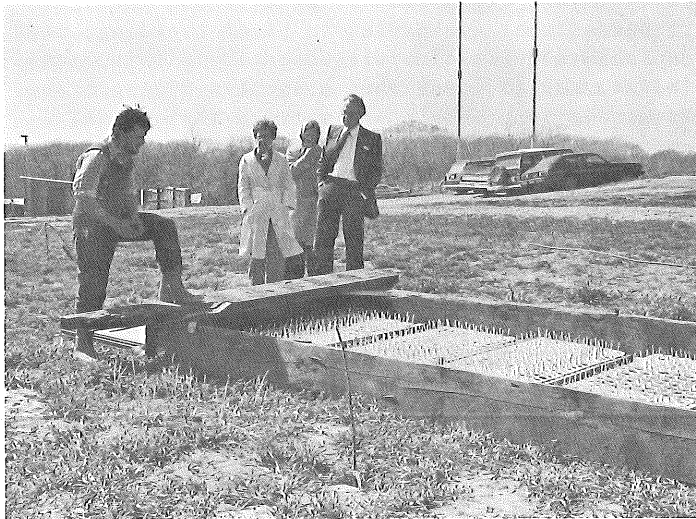

Jim Peterson explains our research to visitors.

Visitor Policy

Visitors are welcome at The Land if they make arrangements ahead of time. We do not have a regular visiting day or a scheduled open house. However, from time to time we host visiting classes or groups from various places on the same day.

Our students generally are not at The Land on weekends, unless there is a special program, and we ask that people not "just drop in" on Saturday and Sunday. However, those who would like to find out more about The Land Institute by seeing it are invited to write or call (913-823-8967) and we will set a mutually agreeable time for the visit.

Calendar

- June 2 - 1:30 P.M. - Annual Meeting of the Board of Directors of The Land Institute.
- June 2 - 4:30 P.M. - PRAIRIE ROOTS/HUMAN ROOTS Program at Evans Ranch.
- June 3 - 10:00 A.M. - Friends of The Land meet Friends of the Earth.
- June 4 - OUR ENERGY FUTURE: Soft Paths vs. Hard Paths. Energy course begins at The Land.
- June 9 - 12 noon - Anti nuclear rally at John Redmond Reservoir near Burlington, Ks.
- June 29 - last day for summer energy course.

The Fall Term begins on September 10. The Land Institute admits students of any race, color, and national or ethnic origin. College credit is available through Marymount College in Salina.

Preserving the Tallgrass Prairie Island

by

Dr. Charles Grimwood

Department of Biology, Marymount College

It is now over 100 years since the first National Park was established. The several dozen natural areas now preserved by the National Park Service are an extension of an ethic which seeks to bring humans and their environment into closer harmony. Setting aside such natural areas is a step toward our maintaining an equilibrium with nature. Many of the major ecosystems of the country are included, but one major gap is the tallgrass prairie, one of the large and highly productive ecosystems of North America. Tallgrass prairie was a spectacular segment of the early American landscape with grass tall enough to reach the hat of a person riding a horse.

Since its settlement in the 19th century, the tallgrass prairie of North America has gotten smaller each year. Its rich, dark soil has largely been converted to agricultural use. From its original size of nearly a quarter of a billion acres, extending from Indiana to the Great Plains and from Canada to Texas, it is now essentially reduced to the Flint Hills of eastern Kansas and a few relatively small, scattered sites elsewhere. It is important that a sample of the remaining tallgrass prairie and each other major ecosystem be included in a National Park. Such natural areas are important to us for a number of reasons, including helping us to learn how to manage our farms and pastures to make them as long lasting as natural ecosystems.

A Tallgrass Prairie National Park and Tallgrass Prairie National Preserve totalling about 300 square miles have been proposed in the Kansas Flint Hills. Suggested alternatives or additions to this single protected area include a scenic parkway or a system of smaller protected areas at scenic sites along a parkway. However, some people say there is no need for any types of protected tallgrass prairie. In their view it is and will continue to be maintained in its original condition. Its present use might simply be perpetuated with land-use zoning, for example.

This disagreement is of political, social and scientific importance. Hopefully this paper will provide a clear perspective of the issue, particularly from a viewpoint of biological conservation. A key concept that will be forwarded is that nature preserves are islands for living organisms which can exist in a changing world.

Supporters of the proposed National Park and Preserve consider the life that inhabited the primeval prairie, and the sights, sounds, odors and history of this core of North America worthy of protection. The feel of standing in the midst

of a windswept sea of grass, which many of our ancestors knew as they lived on or traveled through these tallgrass prairies, is something supporters of the Park say should be felt by all Americans today and in the future. A National Park would guarantee this possibility; the park system was established to preserve scenic, educational and scientific values found in representative portions of our land. There are indeed many social, political and economic arguments for and against the Park to be considered. The case for a park has been presented by Duncan (1) and Coggins and McCloskey (2).

PRESERVING NON-HUMAN LIFE

I wish to focus on a specifically biological issue relating to the tallgrass prairie controversy. How can we best preserve the diverse forms of life native to the prairie for the benefit of our own and future generations? One goal of a National Park, large or small, would be to preserve the native life of the tallgrass prairie.

Why should a human be concerned about preserving non-human life? We humans share a common origin with other organisms and we find inspiration and beauty in many of them. More practically, other organisms are genetic and chemical resources that are useful in plant breeding, pest control and biomedical research (3). This means that humankind loses when a species disappears. No wonder some people are worried that mammal species now go extinct at a rate per year nearly fifty times that of only 200 years ago (4).

A less human-centered viewpoint argues that natural objects should possess some rights in a legal sense (5). Do we humans possess an unqualified right, either legally or ethically, to deprive other species of continued existence?

Preserving living diversity is a worthy goal for several reasons. What then is a useful strategy for achieving that goal? For this discussion I shall delineate this question into three levels: preservation of genes and populations, species, and interacting communities.

Genetic variability in populations is the raw material of evolution. It is equally necessary in the breeding of domesticated animals and plants. However, modern agriculture with its emphasis on breeding uniform, high-producing varieties often erodes gene diversity in those very organisms (6). Enlightened self-interest dictates that we recognize the danger in losing genetic variants that are essential to meeting long-term

human needs. In fact, the National Research Council (7) concluded that efforts at preserving genetic variation must focus on preserving large populations of organisms, rather than merely a few breeders. Organisms native to the tallgrass prairie, for example, may contain genes vital to the breeding of new crop varieties or to the stability and improvement of existing ones.

The extinction of diversity at the gene and population level can be a step toward extinction at the species level. The loss of any species can be seen as hazardous to humans for several reasons. There is, of course, the aesthetic or religious reason that the beauty of the planet is diminished when a species is lost. Another reason is for the use, either current or potential, of a species in science and technology applied to human needs. A third compelling argument is that it is extremely difficult to predict the long-term consequences of simplifying living ecosystems by losing species. One possible consequence is that outbreaks of pests after the extinction of a predator might occur.

Preservation at the third level of diversity follows logically from the first two. An ecosystem is simplified when a species is lost. Simplified communities may be unstable communities. Loss of either organisms or habitat may result in other organisms or habitats being lost, because a species or a population may not survive when deprived of the diverse, complex community in which it evolved. The most productive method for protecting endangered or threatened species is through preservation of sufficient suitable habitat (8).

WHY PRESERVE PRAIRIE?

How do these broad statements apply more specifically to prairie preservation? The tallgrass prairie is an important reservoir of genes because it contains many economically useful organisms, particularly plants. The ecosystem is used as pasture and hay. The dominant grass species are used as seed crops. Future food crops may be developed from prairie plants, such as eastern gamma grass (9). The loss of gene variability in a dominant plant species would have profound economic and ecological effects.

The tallgrass prairie has already lost some species. The wapiti (American elk) and bison are examples. Grazing by cattle has altered the relative abundance of plant species. Replacing prairie species with domesticated plants, for example food or hay crops, has simplified tallgrass prairie. It is therefore vital that some of the prairie's diversity be retained as we continue to alter this once vast ecosystem.

Not all natural communities that existed when humans first reached North America can be preserved in their primitive form. The key is to pinpoint the proper level of diversity preservation between 100% wilderness and 100% human

changed ecosystems. But why worry about prairie?

Perhaps a historical sketch of my own perspective toward National Parks and the tallgrass prairie will be instructive. Most years of my life have been spent in or near the Flint Hills. At first I, as Aldo Leopold said concerning aesthetics (10), defined scenery only in terms of mountains and pine trees and did not fully see the other quality that surrounded me. My initial view of National Parks developed somewhat from this perspective of what "scenery" was worthy of Park status. It was not until I studied National Parks in depth and had worked at Mount Rainier National Park, Washington, that a more encompassing view of a National Park really became implanted in my mind. Many Parks, indeed nature preserves of all types, are fast becoming islands of beauty and diversity in a technologically-altered world. The striking contrast I experienced as I crossed the boundary into Mount Rainier enforced this broadening definition. This glaciated volcano and its surrounding tundra and forest are nearly isolated among the logging and commercial developments of the Cascade Mountains. It is an island in the truest sense of the word.

Is not the native tallgrass prairie in a similar situation? This once vast prairie has been reduced essentially to a Flint Hills island by extensive farming, road building and urbanization, and tallgrass prairie reduction continues with the invasion of trees if prairie fires are extinguished. It continues when pasture grasses not native to this prairie are planted to replace the native species. It continues when pipelines and microwave towers are constructed. The Flint Hills prairie that my ancestors homesteaded in the 19th century are not the same I experienced as a boy. The Flint Hills I hiked, camped and loved years ago are not the hills of today.

In my case it took time away from those hills and a period of reflection and study to recognize the forces that are inexorably changing them. Geologically the Flint Hills have changed little, but biologically they have changed. A "busted" section of prairie sod planted to wheat is a striking biological change. But, several thousand acres replanted into fescue west of Topeka or the decline in native wildlife and plant species, even after well-managed cattle grazing, may not be nearly so obvious to the untuned eye.

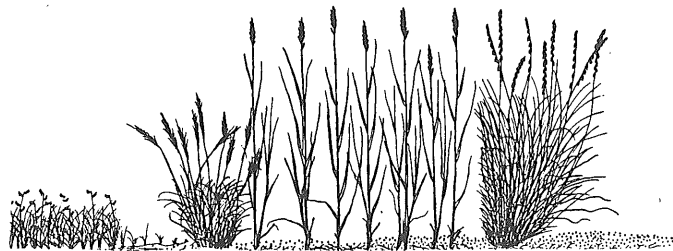

THE TALLGRASS ISLAND

A biological island may be classical, in the sense of land surrounded by water, or more abstract, but nonetheless biologically real, in a mountain surrounded by desert, a lake surrounded by forest or a prairie surrounded by agricultural fields. What factors determine the number of different kinds of organisms that will survive on an island like Mount Rainier or a tallgrass prairie preserve? The number of species on an island seems to represent a dynamic equilibrium between the addition, by immigration or evolution, of organisms to the island and loss, by extinction or emigration, of organisms from the island (11).

A relationship has been observed between island size and number of species. A rough rule is that a tenfold reduction in island area corresponds to a halving of the equilibrium number of species present (12). Very roughly speaking, therefore, one could predict that in a sea of altered prairie a tallgrass park of the size now proposed (about 300 square miles or less than one tenth of one percent of the original 325,000 square miles) would have at equilibrium a number of species equal to about twelve percent that of the original prairie wilderness.

Another factor in the species equilibrium number is the distance of the island from a colonization source. If one were to compare two oceanic or habitat islands of equal size, one would likely find more species on the island near to the "mainland" site from which migrants could inhabit the island. An equilibrium might result through the following scenario. As a new island forms, for example a volcanic island in the ocean, it is colonized by birds. Immigration rate is initially high because every species that lands is a new one. The rate at which new bird species are added will then decrease as the number of species on the island increases; the "pool" of possible species becomes depleted. Conversely, the rate at which bird species go extinct on the island is at first low because there are few species to become extinct. Extinction rate then increases because of increased competition between species and, possibly, predation and disease. An equilibrium results in which addition balances loss. Finally, the larger and less isolated the island, the more species it should contain at equilibrium. Large islands contain more diverse habitats and support larger populations; immigration rates are higher to islands near a mainland than to isolated islands.

An island can be viewed under three broad circumstances: (a) as it approaches its equilibrium through increasing species numbers, such as the newly formed island in an ocean, (b) as it is at equilibrium, and (c) as it approaches equilibrium through losing species, such as when a moist forest island shrinks as it is invaded by a growing desert. Islands of tallgrass prairie fit the third circumstance. The size of the tall-

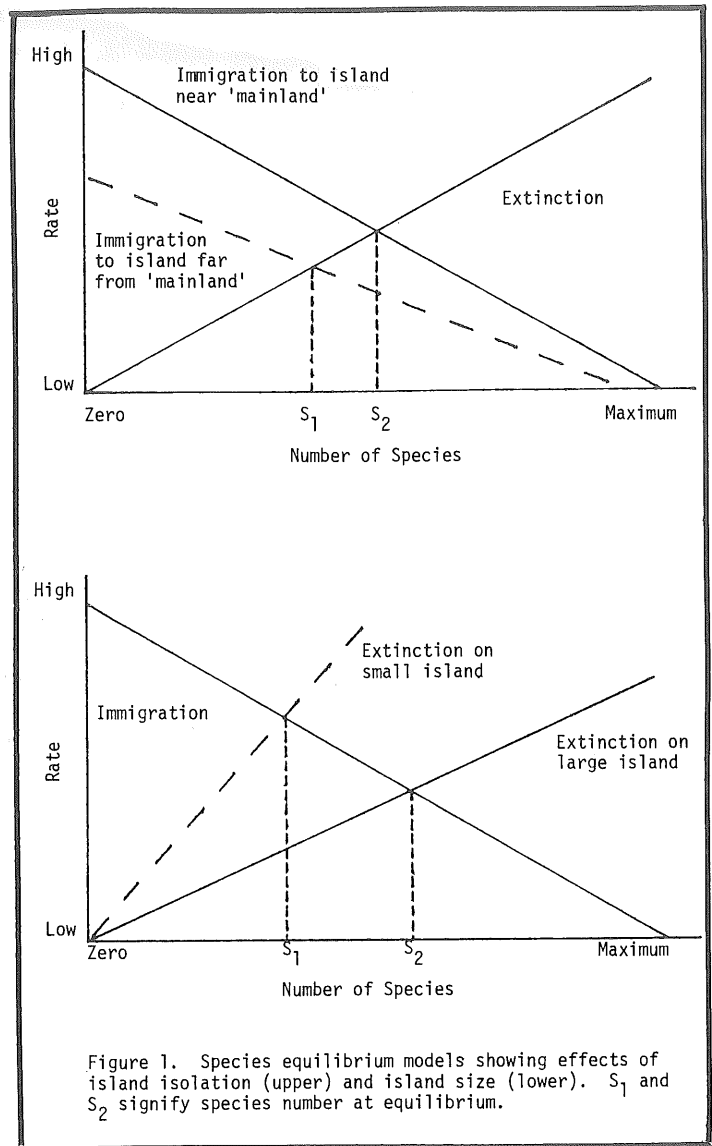

Figure 1. Species equilibrium models showing effects of island isolation (upper) and island size (lower). S_1 and S_2 signify species number at equilibrium.

grass "island" on our continent is shrinking as it is "invaded" by plows, fescue, cattle and human-kind.

PRESERVING THE TALLGRASS ISLAND

Proposals for the Tallgrass Prairie National Park and Preserve should be evaluated from the island equilibrium perspective. What is the likely number of genes, species and communities that will be retained in a park of given size, shape and isolation? Will a strip of small prairie islands along a scenic parkway equal a single, large park in terms of biological diversity? Should society preserve 300 parks of one square mile each or one park of 300 square miles? These are vital questions because of their economic and social impact, in addition to their biological importance. And, as you surely suspect, there is no simple answer.

We cannot save all the biological diversity of the primeval tallgrass prairie. What we can do is strive to meet a balance between preserving

biological diversity and agricultural, urban and other uses of the prairies. Many uses are valid. That is, we need both a park and ranches, the same as we need parks as well as homes in cities. The need for a prairie park is no more a criticism of ranchers than a city park is a criticism of homeowners in the city. Cattle ranching in prairie is certainly as valid a use as plowing and planting wheat on prairie land. In fact, it is far better as far as prairie perpetuation is concerned.

If a fraction of the tallgrass prairie were set aside as a preserve and the rest altered by humans, the park would at first be "supersaturated" with species. The number there would have evolved in a prairie much larger in area than that of the preserve. In moving toward a new equilibrium the preserve island would experience an extinction rate higher than the rate at which new organisms migrated onto the island. A resultant decrease in species number towards equilibrium has been documented in land-bridge islands, such as in Japan off Asia and Britain off Europe, as they were separated from the mainland by a rise in sea level after the most recent ice age (13). Similar findings were obtained in a study of mammal species on mountain islands created by expansion of the North American desert (14) and bird species on a forest island created by construction of the Panama Canal (15).

The ultimate equilibrium number of preserved species will be affected also by the respective probabilities of survival of each original species. If they were all equal in this respect, then it could be that a large number of small tallgrass prairie reserves would be as workable as a single large preserve (16). However, it is known that different species have different minimum areas required for survival, based on their capability for migration between islands and on their minimum population size required to avoid extinction. Many plants and animals are quite sedentary, so a local extinction may not be replaced by other members of the species migrating into the habitat. Animals with very large territory requirements, the larger predators like eagles, for example, are typical of species prone to extinction on small islands.

Some large species have already been virtually lost from the tallgrass prairie and remain only where preserved by humans in other ecosystems. Loss of animals like wapiti and bison which in a natural situation require large areas and generally live at low densities, and the loss of "specialist" animals with specialized food or habitat requirements, may lead to "density compensation" (17) where more generalized, smaller species increase in number. Wilson and Willis (18) said that, taken to their extremes, the early loss of specialists and of large species, together with the effects of reducing island area, may "...result in the domination of small parks by rats, cockroaches, sparrows, and similar invaders from nearby human areas." Such a park

would certainly have lost much of its reason for existence.

There is some disagreement among scientists as to the optimal general design for natural reserves. This disagreement, like that in many areas of science, is based on the fact that the theories being applied are relatively new and have not been intensively tested due to lack of data. However, by looking at the design principles proposed (19, 20, 21) and the discussion that is occurring over their validity we can still find important points for use in planning tallgrass prairie preservation.

1. Individual preserves should be as large as feasible in order to minimize extinction rates. However, this principle cannot be generally applied to all natural preserves (22) and will be discussed later.

2. Multiple preserves designed to contain unique prairie habitats or species should be located as closely together as possible. This would facilitate migration among the preserves and maximize the equilibrium species number. Deliberate transplantations of species would also be easier.

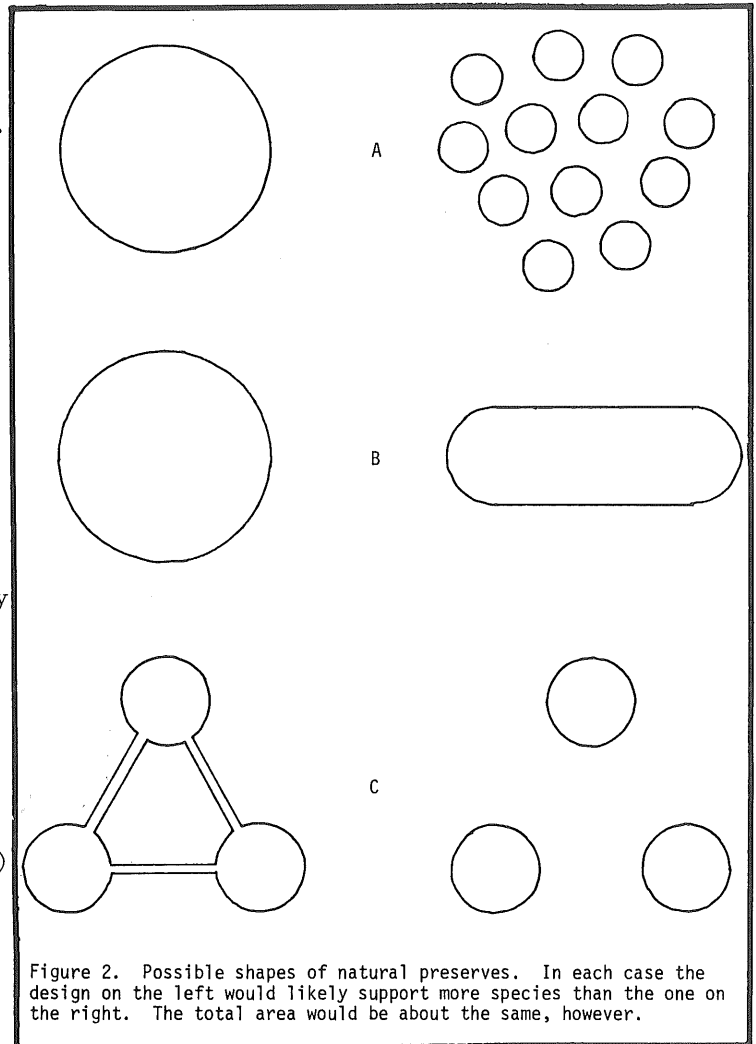

Figure 2. Possible shapes of natural preserves. In each case the design on the left would likely support more species than the one on the right. The total area would be about the same, however.

3. A preserve should be as round in shape as possible. This is because of a "peninsula effect" where dispersal rates to outlying areas in a preserve with a linear shape may be so low as to diminish recolonization following local extinctions (23). Such an effect is seen in a lower number of land bird species on the Florida and Baja California peninsulas relative to comparable non-peninsular areas.

4. Barriers to dispersal, such as power line rights-of-way or roads, should be minimized. A preserve cut into two pieces by a freeway may for some species effectively cut their habitat in half and may also, by increasing extinction, lower the equilibrium number of species for the preserve.

5. Isolation of multiple preserves can be reduced through dispersal corridors or "stepping-stones" of natural habitat between them.

The major point of controversy is the principle of making a preserve as large as possible. An abundance of migration and extinction data on many species would be required in order to know positively whether the tallgrass prairie would be best preserved in a system of several small preserves or a small number of large preserves. Also, in order to optimally preserve genetic variability, it is necessary to know how it is geographically distributed. One species might have geographically widespread populations, each population quite uniform within itself, but quite different from the other populations. Another species might contain widespread populations similar to each other, yet each population might be genetically variable within itself. In the first case a large number of small preserves would be appropriate. Both types of variation have been observed in prairie species (for example 24, 25). However, no accurate statement about the degree to which each type of variation is found in the prairie can be made until further studies are done.

It seems premature to suggest unequivocally either several small sites or one large site as the more desired strategy for the tallgrass prairie. Is it therefore possible to derive any applicable conclusion from theories on island diversity? Yes, when one also considers other factors: 1. some types of tallgrass preserves are already established, 2. inflation is hitting the U. S. economy, and 3. the probability is high for continued alteration of the prairie in the future.

THE PROPOSAL

Making decisions based on too little supportive data is a common problem in a fast-changing technological society. Unfortunately the consequence of delaying decisions makes a wait for more data the worse alternative.

I believe that a decision to support a single,

large Tallgrass Prairie National Park and Preserve is founded in sound reasoning. An ideal situation biologically would be to have a moratorium on further alteration of the tallgrass prairie, a savings account growing at the inflation rate of land prices to hold the money necessary to purchase preserve acreage, and a large staff of ecologists painstakingly studying the extinction and immigration rates, habitat requirements and genetic variability of as many prairie species as possible. However, there is no moratorium, Congressional appropriations for parks are not made that way, and research funding for ecologists doing basic science is very limited.

Tallgrass prairie preserves already established are relatively small and isolated. The largest in the United States is Konza Prairie near Manhattan, Kansas. Its 8,600 acres may seem large when compared with the Clay Prairie in Iowa (less than 3 acres), but it is probably less than 1/20,000th of the size of the original tallgrass prairie. Island prairies like these and others preserved by The Nature Conservancy, as well as preserved prairie acreage near reservoirs, in state parks and on private lands, constitute a significant means of tallgrass prairie preservation. In many ways they meet needs for a system of small preserves. Their major drawbacks may be in differing management goals from a National Park, lack of funding and legal protection, and geographic isolation. They are not National Parks, but needs for small areas may be met through these and similar efforts and may not require the large-scale work that would be needed for a large preserve. The species which require numerous small islands for preservation are partially provided for in these preserves. The focus then shifts to large preserves.

Large, contiguous areas of tallgrass prairie are disappearing. Highways, exotic grass introductions, attempts to develop useable prairie fertilizers, and other forces are breaking the native prairies into smaller and smaller islands. Failure to set aside a large preserve soon will probably make the establishment of such an entity extremely difficult or impossible in the future.

CONCLUSION

It is necessary to focus now on the establishment of a large preserve. As a National Park, this preserve would more broadly encompass the people-oriented educational and scenic objectives than do many of the smaller preserves. The feeling of the vastness of the prairies which the pre-settlement humans encountered would be retained. A suitably large area for the types of organism and gene diversity requiring great space would be saved. The large Park would therefore fulfill many human-oriented needs as well as provide for those species requiring large area. A "large" island one thou-

sandth the size of the original tallgrass prairie does not seem so large after all.

Through efforts to preserve a proposed site in the Kansas Flint Hills as a National Park, through continued protection of unique, small prairie sites scattered across the part of North America that was once a tallgrass prairie wilderness, and through awareness and use of island diversity principles in the planning and management of both types of preserves, the tallgrass prairie will remain an integral part of the American scene. It will not become solely a pasture, devoid of many of the species and the aesthetic quality of the primeval tallgrass prairie, but it will continue as a refuge where we and our descendants can regain those vital feelings of oneness with the land we inhabit and preserve species of value for our welfare. The buildings on my family's homestead will disappear, but the tallgrass prairie can remain. I hope we can allow it to continue into perpetuity as part of the consciousness of our nation (26).

REFERENCES AND NOTES

1. Duncan, P.D. 1978. Tallgrass prairie: the inland sea. The Lowell Press, Kansas City. 113 p.
2. Coggins, G.C., and M. McCloskey. 1977. "New directions for the National Park System: the proposed Kansas Tallgrass Prairie National Park." Kansas Law Review 25:477-543.
3. Harcombe, P.A., and P.L. Marks. 1976. "Species preservation." Sci.
4. Turk, J., J.T. Wittes, R. Wittes, and A. Turk. 1975. Ecosystems, energy, population. W.B. Saunders Co., Philadelphia. 296 p.
5. Stone, C.D. 1975. Should trees have standing? Toward legal rights for natural objects. Avon Books, N.Y. 118 p.
6. Harlan, J.R. 1975. "Our vanishing genetic resources." Sci. 188:618-621.
7. National Research Council. 1978. Conservation of germplasm resources. Nat. Acad. Sci., Wash., D.C. 118 p.
8. Harcombe and Marks.
9. Jackson, W., and M. Bender. 1978. "Alternatives in agriculture." The Land Report 6:6-8.

10. Leopold, A. 1949. A Sand County almanac and sketches here and there. Oxford Univ. Press, N.Y. 226 p.
11. MacArthur, R.H., and E.O. Wilson. 1967. The theory of island biogeography. Princeton Univ. Press, Princeton, N.J. 203 p.
12. Diamond, J.M., and R.M. May. 1976. Island biogeography and the design of natural reserves. In R.M. May (ed.) Theoretical ecology: Principles and applications. W.B. Saunders Co., Philadelphia. 317 p.
13. Ibid.
14. Brown, J.H. 1971. "Mammals on mountaintops: Non-equilibrium insular biogeography." Am. Nat. 105:467-478.
15. Terborgh, J. 1974. "Faunal equilibria and the design of wildlife preserves." In F. Golley and E. Medina (eds.) Tropical ecological systems: trends in terrestrial and aquatic research. Springer, N.Y.
16. Diamond and May.
17. MacArthur, R.H., J.M. Diamond, and J.R. Karr. 1972. "Density compensation in island faunas." Ecol. 53:330-342.
18. Wilson, E.O., and E.O. Willis. 1975. "Applied biogeography." In M.L. Cody and J.M. Diamond (eds.) Ecology and evolution of communities, Belknap Press of Harvard Univ. Press, Cambridge, Mass. 545 p.
19. Diamond and May.
20. Wilson and Willis.
21. Diamond, J.M. 1975. "The island dilemma: lessons of modern biogeographic studies for the design of natural reserves." Biol. Conservation 7:129-146.
22. Simberloff, D.S., and L.G. Abele. 1976. "Island biogeography theory and conservation practice." Sci. 191:285-286.
23. MacArthur and Wilson.
24. McMillan, C. 1967. "Phenological variation within seven transplanted grassland community fractions from Texas and New Mexico." Ecol. 48:807-813.
25. Porter, C.L., Jr. 1966. "An analysis of variation between upland and lowland switchgrass, Panicum virgatum L., in Central Oklahoma." Ecol. 47:980-992.
26. Ideas and criticisms were contributed by Drs. L.C. Hulbert and M.P. Johnson, Sr. J. Sweat and Ms. C. Preston. Only the author can take credit for the errors which remain intact, however.

Friends of The Land

The Friends of The Land have been extremely important to The Land Institute. Many helped collect materials to build the first building; many donated time and labor after that building burned to help start reconstructing the classroom/library/shop. Friends donated books and money to help develop another library. The Land needs these friends, and new friends too.

The Land Institute is a private, educational-research organization, financed by student tuitions and private gifts. Contributors receive THE LAND REPORT, any special publications, and notices of interesting events at The Land. The Land Institute is a non-profit organization, and all gifts are tax deductible.

NAME _____		
ADDRESS _____ _____		
PHONE _____	DATE _____	
(CHECK CATEGORY OF CONTRIBUTION)		
_____ \$10	_____ \$25	_____ \$50
_____ \$100	_____ \$475 (student sponsor)	
_____ \$3 (subscription to THE LAND REPORT only)		

THE COVER DRAWING

The plants in this drawing by Bobbie Fortrun Lively were sketched in the field, to scale, after excavating each plant. The drawing originally appeared in a prize-winning article on prairie restoration in the Landscape Architecture Quarterly.

Bobbie Lively became interested in the prairie when she began taking classes at the Morton Arboretum in Lisle, Illinois. She studied prairie plant identification and botanical illustration and did nature interpretation in the Arboretum educational programs. She is now a project officer for the Environmental Protection Agency, Region V, in Chicago, Illinois. We are grateful to Bobbie Lively for permission to reprint this wonderful drawing on our cover.

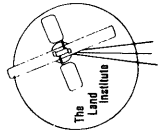

The Land Institute
Rt. 3
Salina, KS 67401

Non-Profit Org.
U.S. Postage Paid
Permit No. 81
Salina, Kansas 67401

(Handwritten notes in pencil, possibly "Lively" and "11/10/81")

